

This electronic document contains the latest available information and therefore varies from the version currently in print.

***Changes are highlighted on the following pages:
33, 38, 40, 41***

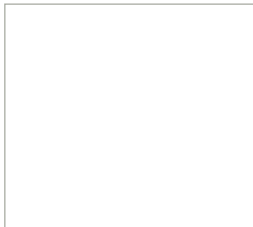
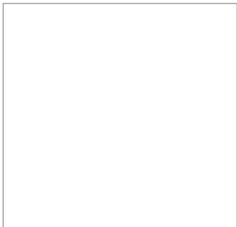
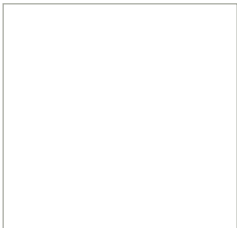

miniature circuit breakers

Think future. Switch to green.



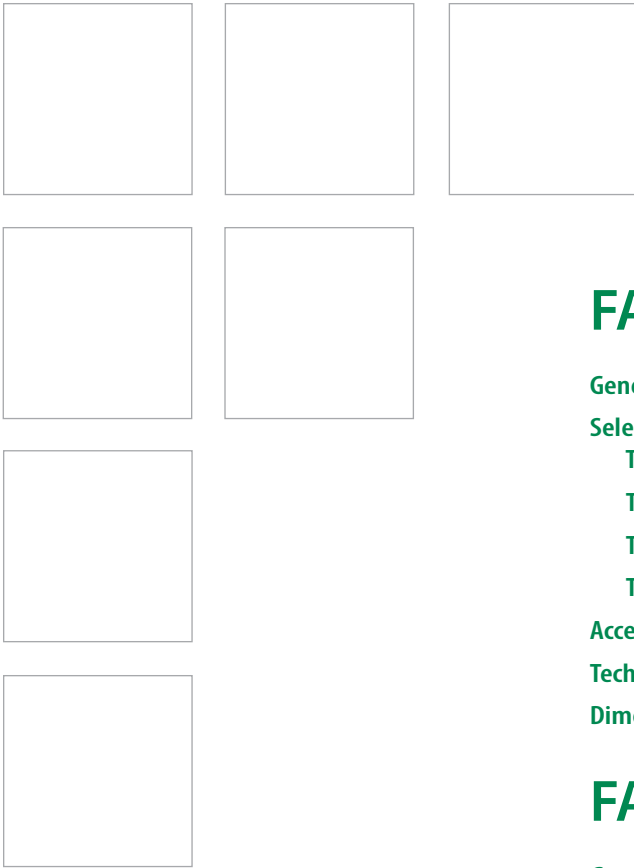

FAZ branch circuit breakers

General Information.....	2
Selection Tables	
Trip Characteristic C - Box terminals.....	4
Trip Characteristic D - Box terminals.....	5
Trip Characteristic C - Ring tongue terminals.....	6
Trip Characteristic D - Ring tongue terminals.....	7
Accessories.....	8
Technical Data.....	10
Dimensions.....	15

FAZ supplementary protectors

General Information.....	20
Selection Tables	
Trip Characteristic B.....	22
Trip Characteristic C.....	24
Trip Characteristic D.....	26
Trip Characteristic K.....	28
Trip Characteristic Z.....	30
Trip Characteristic S.....	31
Accessories.....	32
Technical Data.....	35
Dimensions.....	41

MCB Applications

Applying branch circuit breakers and supplementary protectors in North America	43
--	----

Pricing can be found on the green pages in this catalog.

NEW >>

series FAZ branch circuit breakers

Branch circuit protection up to 10kA

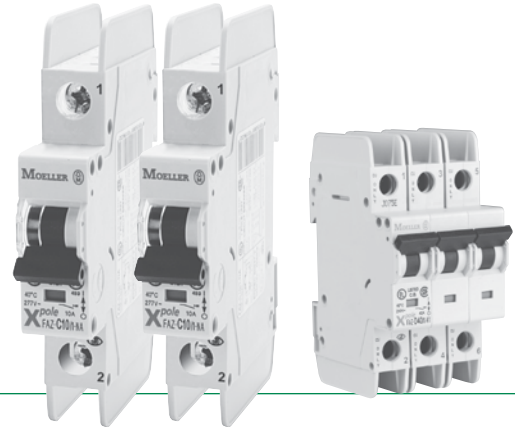

Moeller has just expanded its FAZ line of miniature circuit breakers to include devices that are listed and certified as molded case circuit breakers per UL 489 and CSA 22.2, No. 5-02. These new branch circuit breakers, called FAZ-NA, are ideal for the protection of power supplies, control power transformers, HVAC, refrigeration equipment, florescent lighting (to 20A) and many other applications requiring a primary protective device.

Flexible product range

Moeller's FAZ Branch Circuit Breakers are available in one, two and three pole configurations with 20 different current ratings ranging from 0.5A to 40A. All breakers are available in both C and D tripping curves, offering protection from 5 to 10 and 10 to 20 x the continuous rating of the device (I_n). Two and three pole devices can be used in solidly grounded circuits up to 480V AC. The entire line offers short circuit ratings of 10kA regardless of voltage applied.

See page 43 about...

Applying

FAZ

in North America

- > Molded case circuit breaker per UL 489 / CSA 22.2 No. 5.1
- > Current limiting device
- > Ring-tongue terminals available
- > Worldwide approvals

Many installation options

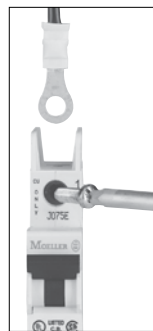

FAZ Branch Circuit Breakers are available in two terminal configurations; standard box terminals that accept multiple conductors and ring-tongue terminals, ideally suited to the demanding requirements of the semi-conductor industry. All breakers mount on standard 35mm DIN-rail. Bus Connectors and Feeder Terminals facilitate mounting and wiring of multiple miniature circuit breaker arrays in control panel assemblies. Power to the circuit breakers can also be fed from the line or load side.

Standard features enhance safety

As with most products from Moeller, FAZ breaker terminals provide finger and back-of-hand protection to guard against accidental contact with live parts. A color-coded red/green indicator provides immediate visual indication of device status and isolation function (green for OFF, red for ON). All FAZ breakers incorporate a "trip-free" mechanism. This prevents the trip function from being defeated by holding the operator in the ON position. In addition, all FAZ branch circuit breakers are UL listed and CSA certified for *fuseless* protection of smaller AWG 18 and 16 conductors!

Worldwide acceptance

FAZ-NA (RT) Molded Case Circuit Breakers are UL Listed for use in the United States in accordance with NFPA 70 (NEC). The devices comply with UL 489 and CSA 22.2 No. 5-02, meeting the requirements for Molded Case Circuit Breakers. These devices also comply with IEC 60947-2 and are CE compliant.

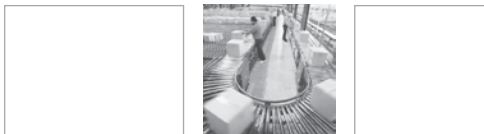



Tripping characteristics

Moeller FAZ-NA(RT) branch circuit breakers are available with “C” and “D” tripping characteristics. C-curve devices are suitable for applications where medium levels of inrush current are expected. Applications include small transformers, lighting, pilot devices, control circuits, and coils. C-curve devices provide a medium magnetic trip point.

Devices with a “D” curve are suitable for applications where high levels of inrush current are expected. The high magnetic trip point prevents nuisance tripping in high inductive applications such as motors, transformers, and power supplies.

Even though not required by NEC or CEC for Branch Circuit Breakers, Moeller’s FAZ-NA(RT) devices are current limiting, which means they interrupt fault currents within one half cycle of the fault. Current limiting devices offer superior protection by reducing peak let-through current and energy.

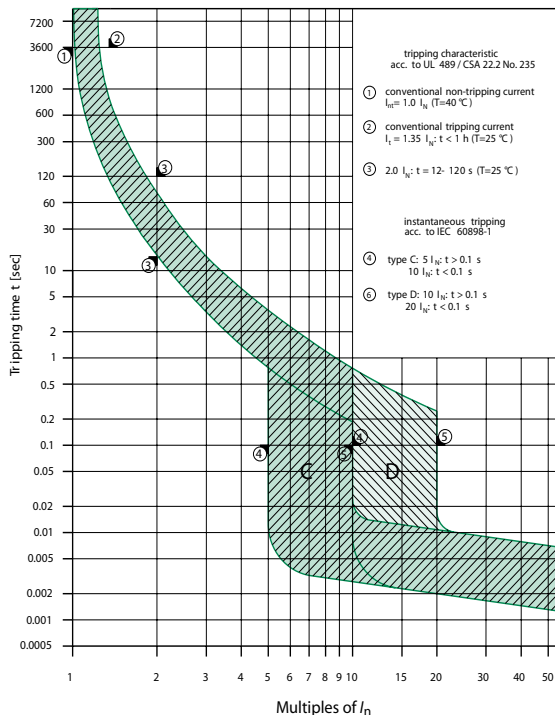

This graph shows trip-time versus over-current for Type C and D devices FAZ-NA branch circuit breakers.

Discover these advanced features

Available in one, two and three poles with “C” & “D” trip characteristics

Arc Chutes quickly extinguish arcs generated by the opening of the contacts under normal or high fault conditions

Arc chutes and switching mechanism are kept apart for mechanical reliability

Breakers install on standard DIN-rail

Bimetal trip assembly provides reliable overload protection through a broad range of ambient temperatures

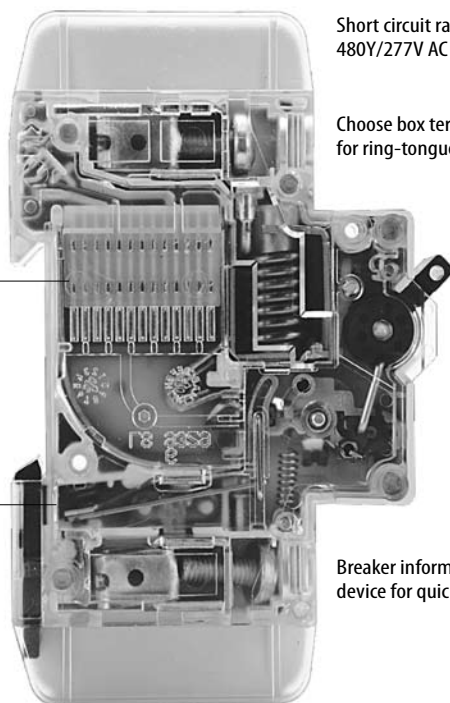

Short circuit rating to 10kA (@277V AC and 480Y/277V AC for multi-pole) –

Choose box terminals (AWA #18 to #4) or terminals for ring-tongue connectors

Complete bus bar system available for quickly installing breaker arrays

Trip-free design; breaker cannot be defeated by holding the handle in the ON position

Color coded indicator provides breaker status for easy troubleshooting

Breaker information printed on the front of the device for quick identification

Trip Characteristic C

- > UL Approved (UL489) and CSA Certified (CSA C22.2 No. 5-02) as Branch Circuit Breakers
- > Interrupting capacity: 10kA UL/CSA; 15kA IEC 60947
- > Trip characteristic C: Response time of instantaneous trip: 5 – 10 x I_n current rating
- > Current limiting device

Type C Characteristics

Suitable for applications where medium levels of inrush current are expected. Instantaneous trip is 5 to 10 x rating of device (I_n). Applications include small transformers, lighting, pilot devices, control circuits, and coils. Medium magnetic trip point.

Trip Characteristic C – Designed for inductive loads

Rated Current I_n (A)	1 pole		2 poles		3 poles	
	Type	Price	Type	Price	Type	Price
0.5	FAZ-C0,5/1-NA	See green pages	FAZ-C0,5/2-NA	See green pages	FAZ-C0,5/3-NA	See green pages
1	FAZ-C1/1-NA		FAZ-C1/2-NA		FAZ-C1/3-NA	
1.5	FAZ-C1,5/1-NA		FAZ-C1,5/2-NA		FAZ-C1,5/3-NA	
2	FAZ-C2/1-NA		FAZ-C2/2-NA		FAZ-C2/3-NA	
3	FAZ-C3/1-NA		FAZ-C3/2-NA		FAZ-C3/3-NA	
4	FAZ-C4/1-NA		FAZ-C4/2-NA		FAZ-C4/3-NA	
5	FAZ-C5/1-NA		FAZ-C5/2-NA		FAZ-C5/3-NA	
6	FAZ-C6/1-NA		FAZ-C6/2-NA		FAZ-C6/3-NA	
7	FAZ-C7/1-NA		FAZ-C7/2-NA		FAZ-C7/3-NA	
8	FAZ-C8/1-NA		FAZ-C8/2-NA		FAZ-C8/3-NA	
10	FAZ-C10/1-NA		FAZ-C10/2-NA		FAZ-C10/3-NA	
13	FAZ-C13/1-NA		FAZ-C13/2-NA		FAZ-C13/3-NA	
15	FAZ-C15/1-NA		FAZ-C15/2-NA		FAZ-C15/3-NA	
16	FAZ-C16/1-NA		FAZ-C16/2-NA		FAZ-C16/3-NA	
20	FAZ-C20/1-NA		FAZ-C20/2-NA		FAZ-C20/3-NA	
25	FAZ-C25/1-NA		FAZ-C25/2-NA		FAZ-C25/3-NA	
30	FAZ-C30/1-NA		FAZ-C30/2-NA		FAZ-C30/3-NA	
32	FAZ-C32/1-NA		FAZ-C32/2-NA		FAZ-C32/3-NA	
35	FAZ-C35/1-NA		FAZ-C35/2-NA		FAZ-C35/3-NA	
40	FAZ-C40/1-NA		FAZ-C40/2-NA		FAZ-C40/3-NA	

See Trip Curve chart on page 11

- > UL Approved (UL489) and CSA Certified (CSA C22.2 No. 5-02) as Branch Circuit Breakers
- > Interrupting capacity: 10kA UL/CSA; 15kA IEC 60947
- > Trip characteristic D: Response time of instantaneous trip: 10 – 20 x I_n current rating
- > Current limiting device

Type D Characteristics

Suitable for applications where high levels of inrush current are expected. Instantaneous trip is 10 to 20 x rating of device (I_n). The high magnetic trip point prevents nuisance tripping in high inductive applications such as motors, transformers, and power supplies.

Trip Characteristic D – Designed for highly inductive loads

Rated Current I_n (A)	1 pole		2 poles		3 poles	
	Type	Price	Type	Price	Type	Price
0.5	FAZ-D0,5/1-NA	See green pages	FAZ-D0,5/2-NA	See green pages	FAZ-D0,5/3-NA	See green pages
1	FAZ-D1/1-NA		FAZ-D1/2-NA		FAZ-D1/3-NA	
1.5	FAZ-D1,5/1-NA		FAZ-D1,5/2-NA		FAZ-D1,5/3-NA	
2	FAZ-D2/1-NA		FAZ-D2/2-NA		FAZ-D2/3-NA	
3	FAZ-D3/1-NA		FAZ-D3/2-NA		FAZ-D3/3-NA	
4	FAZ-D4/1-NA		FAZ-D4/2-NA		FAZ-D4/3-NA	
5	FAZ-D5/1-NA		FAZ-D5/2-NA		FAZ-D5/3-NA	
6	FAZ-D6/1-NA		FAZ-D6/2-NA		FAZ-D6/3-NA	
7	FAZ-D7/1-NA		FAZ-D7/2-NA		FAZ-D7/3-NA	
8	FAZ-D8/1-NA		FAZ-D8/2-NA		FAZ-D8/3-NA	
10	FAZ-D10/1-NA		FAZ-D10/2-NA		FAZ-D10/3-NA	
13	FAZ-D13/1-NA		FAZ-D13/2-NA		FAZ-D13/3-NA	
15	FAZ-D15/1-NA		FAZ-D15/2-NA		FAZ-D15/3-NA	
16	FAZ-D16/1-NA		FAZ-D16/2-NA		FAZ-D16/3-NA	
20	FAZ-D20/1-NA		FAZ-D20/2-NA		FAZ-D20/3-NA	
25	FAZ-D25/1-NA		FAZ-D25/2-NA		FAZ-D25/3-NA	
30	FAZ-D30/1-NA		FAZ-D30/2-NA		FAZ-D30/3-NA	
32	FAZ-D32/1-NA		FAZ-D32/2-NA		FAZ-D32/3-NA	
35	FAZ-D35/1-NA		FAZ-D35/2-NA		FAZ-D35/3-NA	
40	FAZ-D40/1-NA		FAZ-D40/2-NA		FAZ-D40/3-NA	

See Trip Curve chart on page 11

Trip Characteristic C

- > UL Approved (UL489) and CSA Certified (CSA C22.2 No. 5-02) as Branch Circuit Breakers
- > Connections for ring-tongue terminals
- > Trip characteristic C: Response time of instantaneous trip: 5 – 10 x I_n current rating
- > Interrupting capacity: 10kA UL/CSA; 15kA IEC 60947

Type C Characteristics

Suitable for applications where medium levels of inrush current are expected. Instantaneous trip is 5 to 10 x rating of device (I_n). Applications include small transformers, lighting, pilot devices, control circuits, and coils. Medium magnetic trip point.

Trip Characteristic C – Designed for inductive loads

Rated Current I_n (A)	1 pole		2 poles		3 poles	
	Type	Price	Type	Price	Type	Price
0.5	FAZ-C0,5/1-RT	See green pages	FAZ-C0,5/2-RT	See green pages	FAZ-C0,5/3-RT	See green pages
1	FAZ-C1/1-RT		FAZ-C1/2-RT		FAZ-C1/3-RT	
1.5	FAZ-C1,5/1-RT		FAZ-C1,5/2-RT		FAZ-C1,5/3-RT	
2	FAZ-C2/1-RT		FAZ-C2/2-RT		FAZ-C2/3-RT	
3	FAZ-C3/1-RT		FAZ-C3/2-RT		FAZ-C3/3-RT	
4	FAZ-C4/1-RT		FAZ-C4/2-RT		FAZ-C4/3-RT	
5	FAZ-C5/1-RT		FAZ-C5/2-RT		FAZ-C5/3-RT	
6	FAZ-C6/1-RT		FAZ-C6/2-RT		FAZ-C6/3-RT	
7	FAZ-C7/1-RT		FAZ-C7/2-RT		FAZ-C7/3-RT	
8	FAZ-C8/1-RT		FAZ-C8/2-RT		FAZ-C8/3-RT	
10	FAZ-C10/1-RT		FAZ-C10/2-RT		FAZ-C10/3-RT	
13	FAZ-C13/1-RT		FAZ-C13/2-RT		FAZ-C13/3-RT	
15	FAZ-C15/1-RT		FAZ-C15/2-RT		FAZ-C15/3-RT	
16	FAZ-C16/1-RT		FAZ-C16/2-RT		FAZ-C16/3-RT	
20	FAZ-C20/1-RT		FAZ-C20/2-RT		FAZ-C20/3-RT	
25	FAZ-C25/1-RT		FAZ-C25/2-RT		FAZ-C25/3-RT	
30	FAZ-C30/1-RT		FAZ-C30/2-RT		FAZ-C30/3-RT	
32	FAZ-C32/1-RT		FAZ-C32/2-RT		FAZ-C32/3-RT	
35	FAZ-C35/1-RT		FAZ-C35/2-RT		FAZ-C35/3-RT	
40	FAZ-C40/1-RT		FAZ-C40/2-RT		FAZ-C40/3-RT	



All breakers on this page are equipped with terminals that accommodate ring-tongue connectors.

See Trip Curve chart on page 11

- > UL Approved (UL489) and CSA Certified (CSA C22.2 No. 5-02) as Branch Circuit Breakers
- > Connections for ring-tongue terminals
- > Trip characteristic D: Response time of instantaneous trip: 10 – 20 x I_n current rating
- > Interrupting capacity: 10kA UL/CSA; 15kA IEC 60947

Type D Characteristics

Suitable for applications where high levels of inrush current are expected. Instantaneous trip is 10 to 20 x rating of device (I_n). The high magnetic trip point prevents nuisance tripping in high inductive applications such as motors, transformers, and power supplies.

Trip Characteristic D – Designed for highly inductive loads

Rated Current I_n (A)	1 pole		2 poles		3 poles	
	Type	Price	Type	Price	Type	Price
0.5	FAZ-D0,5/1-RT	See green pages	FAZ-D0,5/2-RT	See green pages	FAZ-D0,5/3-RT	See green pages
1	FAZ-D1/1-RT		FAZ-D1/2-RT		FAZ-D1/3-RT	
1.5	FAZ-D1,5/1-RT		FAZ-D1,5/2-RT		FAZ-D1,5/3-RT	
2	FAZ-D2/1-RT		FAZ-D2/2-RT		FAZ-D2/3-RT	
3	FAZ-D3/1-RT		FAZ-D3/2-RT		FAZ-D3/3-RT	
4	FAZ-D4/1-RT		FAZ-D4/2-RT		FAZ-D4/3-RT	
5	FAZ-D5/1-RT		FAZ-D5/2-RT		FAZ-D5/3-RT	
6	FAZ-D6/1-RT		FAZ-D6/2-RT		FAZ-D6/3-RT	
7	FAZ-D7/1-RT		FAZ-D7/2-RT		FAZ-D7/3-RT	
8	FAZ-D8/1-RT		FAZ-D8/2-RT		FAZ-D8/3-RT	
10	FAZ-D10/1-RT		FAZ-D10/2-RT		FAZ-D10/3-RT	
13	FAZ-D13/1-RT		FAZ-D13/2-RT		FAZ-D13/3-RT	
15	FAZ-D15/1-RT		FAZ-D15/2-RT		FAZ-D15/3-RT	
16	FAZ-D16/1-RT		FAZ-D16/2-RT		FAZ-D16/3-RT	
20	FAZ-D20/1-RT		FAZ-D20/2-RT		FAZ-D20/3-RT	
25	FAZ-D25/1-RT		FAZ-D25/2-RT		FAZ-D25/3-RT	
30	FAZ-D30/1-RT		FAZ-D30/2-RT		FAZ-D30/3-RT	
32	FAZ-D32/1-RT		FAZ-D32/2-RT		FAZ-D32/3-RT	
35	FAZ-D35/1-RT		FAZ-D35/2-RT		FAZ-D35/3-RT	
40	FAZ-D40/1-RT		FAZ-D40/2-RT		FAZ-D40/3-RT	



All breakers on this page are equipped with terminals that accommodate ring-tongue connectors.

See Trip Curve chart on page 11

For all FAZ...NA and FAZ...RT Miniature Circuit Breakers

Accessories	Description	Circuit Diagram	Rated Operational Voltage	Type	Price
	Selectable 2-pole Auxiliary Contact or Auxiliary/Trip-indicating contacts <ul style="list-style-type: none"> – Small selector screw changes mode – Two Form C (changeover) contacts – Installs on left side of FAZ or Shunt Trip – Aux. contacts switch when FAZ is tripped electrically or manually – Trip indicating contact switches only when FAZ is tripped electrically – Test button for electrical tripping function 	<p>Two-pole auxiliary mode</p> <p>Trip indicating mode</p>	230V AC	Z-NHK	See green pages
	Shunt Trip Release <ul style="list-style-type: none"> – Allows remote trip of FAZ – Installs on left side of FAZ 		110-415V AC	FAZ-XAA-NA110-415VAC	
			12-110V AC	FAZ-XAA-NA12-110VAC	
	Padlock Hasp <ul style="list-style-type: none"> – Prevents reactivation of the device during maintenance – Holds one padlock 			IS/SPE-1TE	

Allowable combinations of accessories

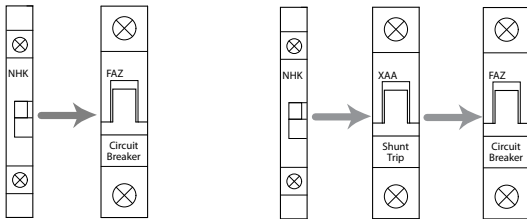

Bus Bar System

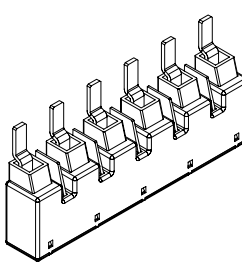
Bus Bar	Number of Poles per Device	Number of Terminals	Rated Operational Current (A)	Type	Price
	1	6	80 A	Z-SV/UL-16/1P-1TE/6	See green pages
		12		Z-SV/UL-16/1P-1TE/12	
		18		Z-SV/UL-16/1P-1TE/18	
	2	6	80A	Z-SV/UL-16/2P-2TE/6	
		12		Z-SV/UL-16/2P-2TE/12	
		18		Z-SV/UL-16/2P-2TE/18	
	3	6	80A	Z-SV/UL-16/3P-3TE/6	
		12		Z-SV/UL-16/3P-3TE/12	
		18		Z-SV/UL-16/3P-3TE/18	

Contact your Moeller representative for availability.

Incoming Supply Terminals

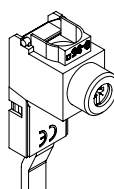
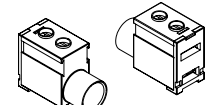
Terminal	Description	Type	Price
	<p>Extension Terminal</p> <ul style="list-style-type: none"> – Accommodates conductors up to 25 mm² (~ AWG 4) – Finger-safe connection 	Z-EK-35/UL	See green pages
	<p>Bus connector</p> <ul style="list-style-type: none"> – For conductors up to 50 mm² (~ AWG 1/0) – Finger-safe connection to Z-SV/UL-16... 	Z-EK-50/UL	

Contact your Moeller representative for availability.

Let-through Energy

Characteristic C (0.5-20A), 277V

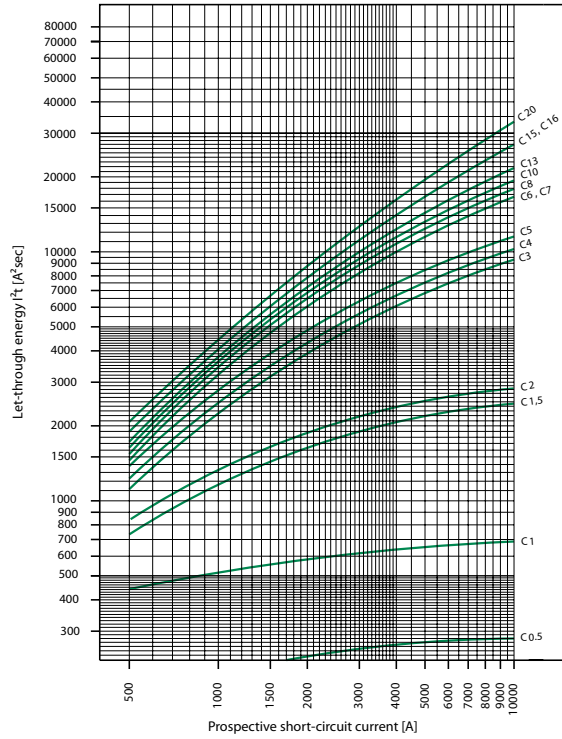

Characteristic C (25-40A), 240V

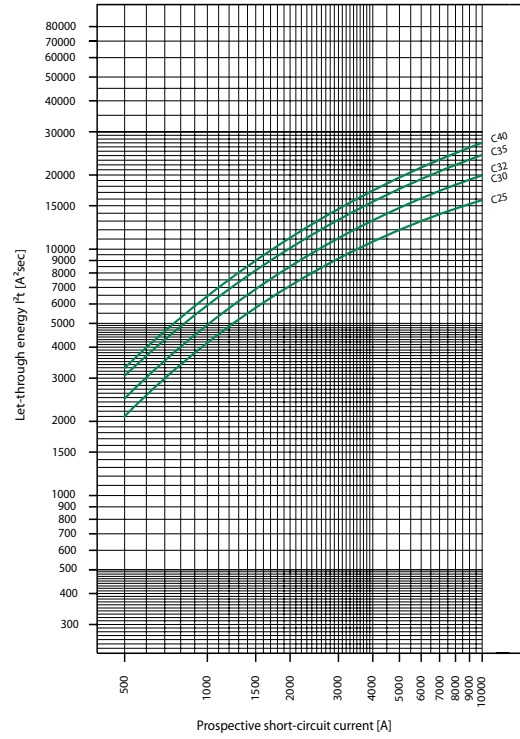

Characteristic D (0.5-20A), 277V

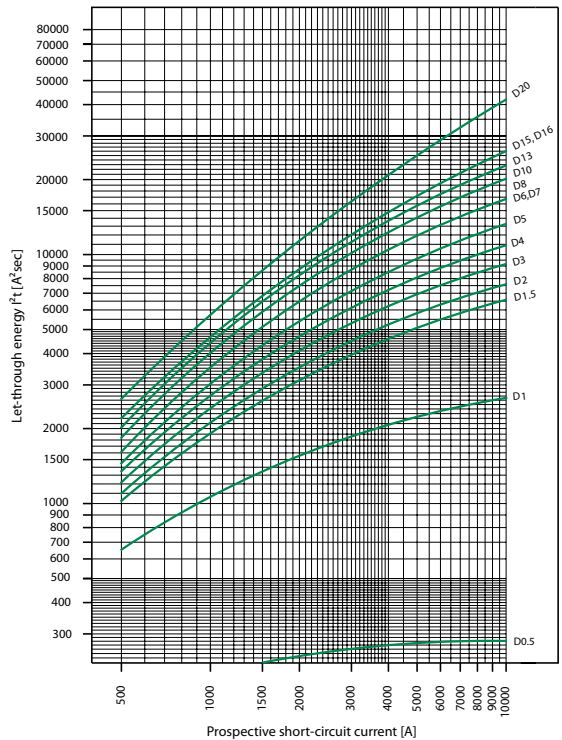

Characteristic D (25-40A), 240V

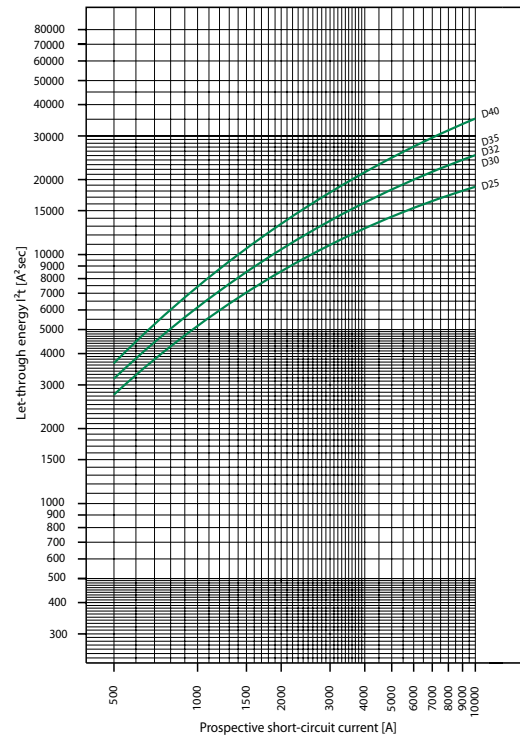

Tripping Characteristics

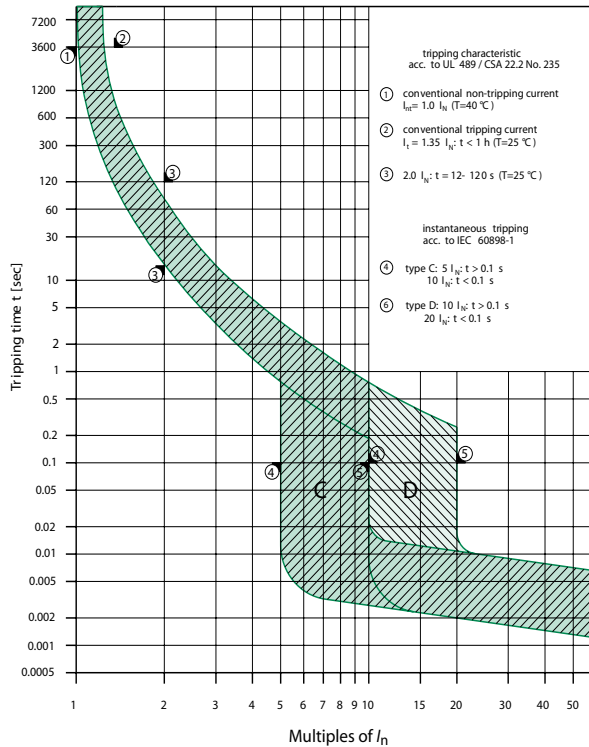

Influence of ambient temperature T on load carrying capacity

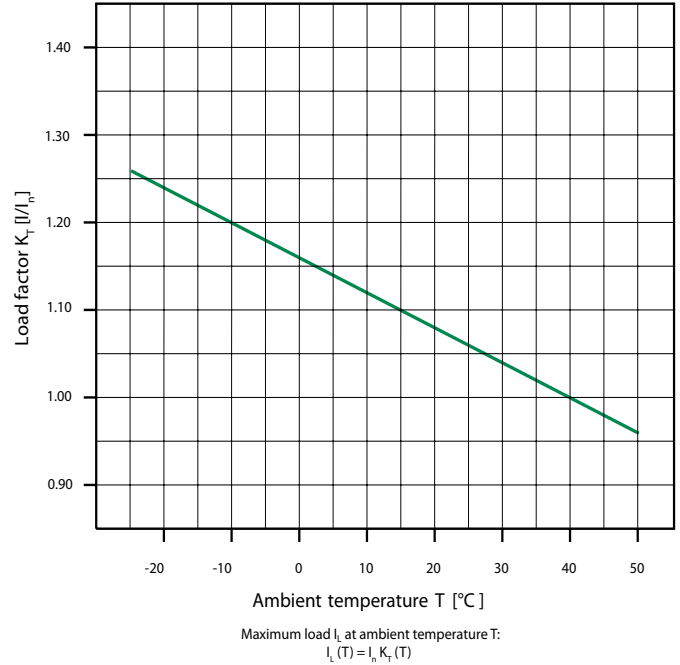

Power loss at I_n

Characteristic C

I_n [A]	1p P[W]	2p P[W]	3p P[W]
0.5	1.6	3.2	4.7
1	1.1	2.2	3.4
1.5	1.3	2.6	3.9
2	1.4	2.8	4.3
3	1.2	2.4	3.6
4	1.4	2.9	4.3
5	1.9	3.7	5.6
6	1.2	2.3	3.5
7	1.4	2.8	4.3
8	1.4	2.8	4.2
10	1.8	3.6	5.3
13	2.4	4.7	7.1
15	1.9	3.8	5.6
16	2.1	4.3	6.4
20	2.9	5.8	8.7
25	3.1	6.2	9.3
30	3.0	6.0	9.0
32	3.4	6.8	10.2
35	3.7	7.4	11.0
40	4.0	8.1	12.1

Characteristic D

I_n [A]	1p P[W]	2p P[W]	3p P[W]
0.5	1.6	3.2	4.8
1	0.8	1.5	2.3
1.5	1.0	2.1	3.1
2	1.0	2.1	3.1
3	1.2	2.4	3.6
4	1.4	2.9	4.3
5	1.5	2.9	4.4
6	1.2	2.3	3.5
7	1.4	2.8	4.3
8	1.2	2.4	3.7
10	1.5	3.0	4.5
13	2.0	4.1	6.1
15	1.5	3.1	4.6
16	1.7	3.5	5.2
20	1.8	3.7	5.5
25	2.6	5.1	7.7
30	2.7	5.4	8.1
32	3.1	6.2	9.3
35	3.8	7.6	11.3
40	3.9	7.8	11.6

FAZ-NA, FAZ-RT Miniature Circuit Breakers

FAZ-NA, FAZ-RT	
Electrical	
Design according to Current test marks as printed onto the device	UL 489, CSA C22.2 No. 5, IEC 60947-2
Rated voltage UL/CSA 0.5 – 20A UL/CSA 25 – 40A IEC	277/480V VAC 240 VAC 240/415 VAC
Rated frequency	50/60 Hz
Rated breaking capacity UL/CSA IEC	10 kA 15 kA
Characteristic Endurance Line voltage connection	C, D ≥ 20,000 operating cycles operational suitable for reverse feed
Mechanical	
Frame size Device height Device width	45 mm 105 mm 17.7 mm per pole
Mounting Upper and lower terminals	quick fastening with 2 lock-in positions on DIN rail EN 50022 open mouth/lift terminals
Terminal capacity	1 Wire AWG 18-6 2 Wires AWG 18-10
Terminal fastening torque	1 Wire 21 lb-in 2 Wires 25 lb-in
Mounting Calibration temperature UL 489, CSA C22.2 No. 5 IEC 60947-2	independent of position 40°C 30°C

Selectable Aux Contact / Trip Indicating Contact – Z-NHK

		Z-NHK
Electrical		
Can be mounted from the left onto: Contact function		FAZ-NA, FAZ-RT, FAZ-XAA-NA 2 changeover contacts (self cleaning)
Rated voltage	[V]	230
Rated frequency	[Hz]	50/60
Rated current	[A]	2
Rated thermal current I_{th}	[A]	2
Utilization category AC13		
Rated operational current I_e	[A]	3 / 250V AC
Utilization category AC15		
Rated operational current I_e	[A]	2 / 250V AC
Utilization category DC12		
Rated operational current I_e	[A]	0.5 / 110V DC
Rated insulation voltage U_i	[VAC]	250
Minimum operational voltage per contact U_{min}	[VDC]	5
Minimum operational current I_{min}	[mA]	10 mA DC
Rated peak withstand voltage U_{imp} (1.2/50 μ)	[kV]	2.5
Conditional short-circuit current I_k with back-up fuse 6A Max. back-up fuse, overload and short-circuit	[kA]	1 kA 6A gL
Mechanical		
Tripping indicator "electrical tripping"		blue/white
Frame size		45 mm
Device height		80 mm
Device width		8.8 mm (0.5MU)
Mounting		Snaps on to side of MCB
Degree of protection, built-in		IP40
Terminal protection		finger and hand-touch safe according to BGV A3, ÖVE-EN 6
Terminals		lift terminals
Terminal capacity		18-14 AWG
Terminal screws		M3 (Pozidrive Z0)
Fastening torque of terminal screws		7 lb-in

Shunt Trip Release FAZ-XAA-NA

	FAZ-XAA-NA12-110VAC	FAZ-XAA-NA110-415VAC
Electrical		
Can be mounted onto	FAZ-NA, FAZ-RT	FAZ-NA, FAZ-RT
Operational voltage range	12-110V AC 12-60V DC	110-415V AC 110-230V DC
Frequency	50/60 Hz	50/60 Hz
Possible standard auxiliary switch	Z-NHK	Z-NHK
Mechanical		
Frame size	45 mm	45 mm
Device height	105 mm	105 mm
Device width	17.5 mm (1MU)	17.5 mm (1MU)
Mounting	quick fastening with 2 lock-in positions on DIN rail EN 50022	quick fastening with 2 lock-in positions on DIN rail EN 50022
Degree of protection, built-in	IP40	IP40
Terminal protection	finger and hand-touch safe according to BGV A3, ÖVE-EN 6	finger and hand-touch safe according to BGV A3, ÖVE-EN 6
Terminals	box/lift	box/lift
Terminal capacity 1 and 2 wires	AWG 18-10	AWG 18-10

Bus Bar ①

	Z-SV/UL-16...
Electrical	
Rated voltage	690V
Rated current	80A
Short-circuit strength	< 25 kA
Overvoltage category	III
Impulse voltage strength	≥ 9.5 kV
Mechanical	
Bus bar cross-section	16 mm ² Cu
Step distance	17.6 mm
Climatic stability	according to DIN EN 60068
Flame class according to UL	V0/0.4 mm
Pollution degree	2

① Contact your Moeller representative for availability.

FAZ-NA, FAZ-RT

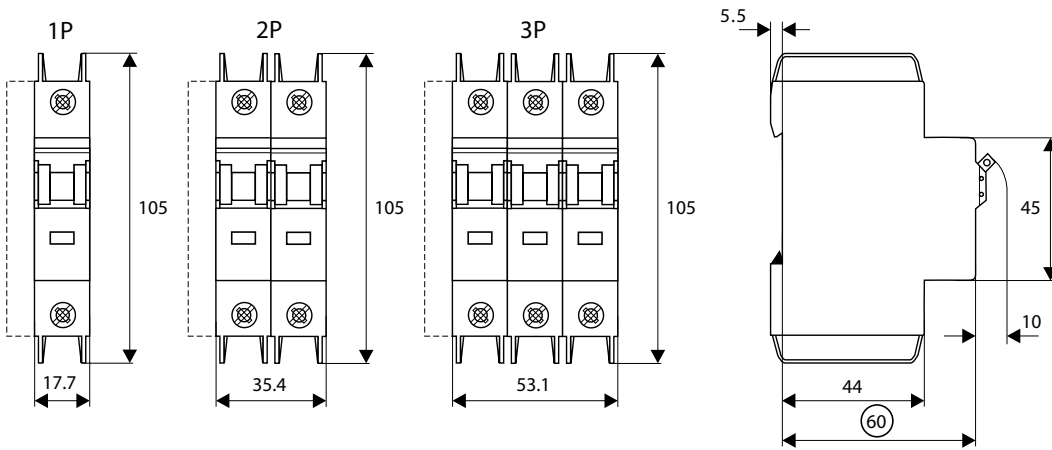

Z-NHK

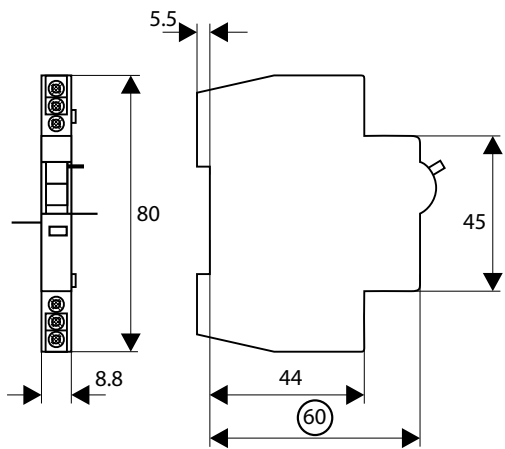

FAZ-XAA-NA

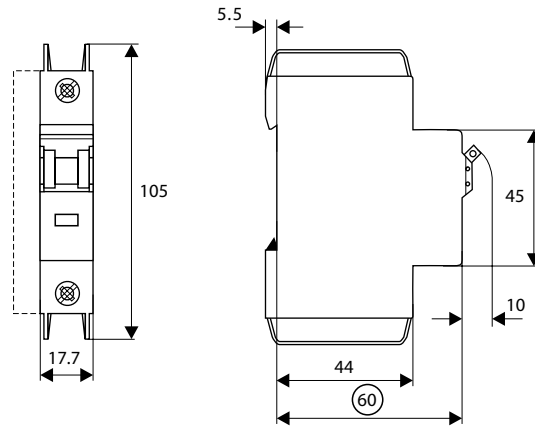

Z-SV/UL-16/P-.TE/6

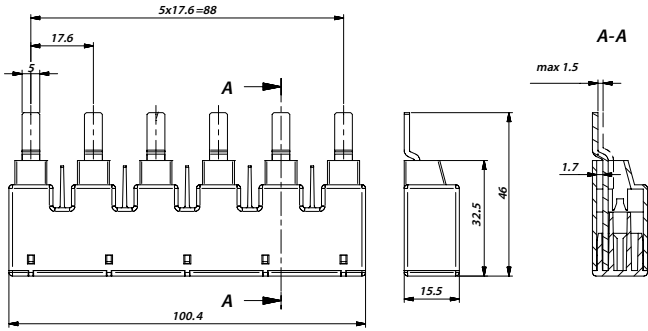

Z-SV/UL-16/P-.TE/12

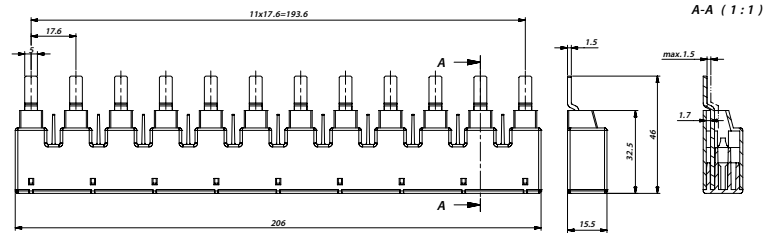

Z-SV/UL-16/P-.TE/18

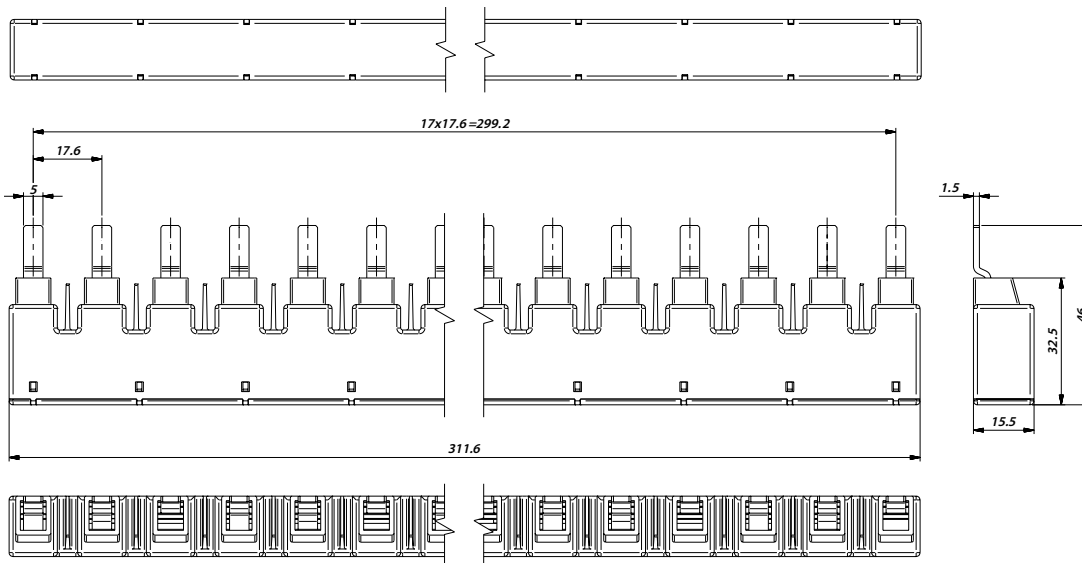

Incoming Supply Terminals

Z-EK/35/UL

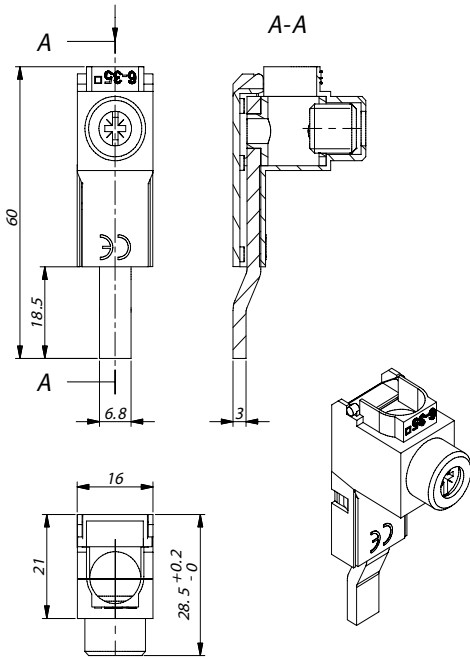

Z-EK/50/UL

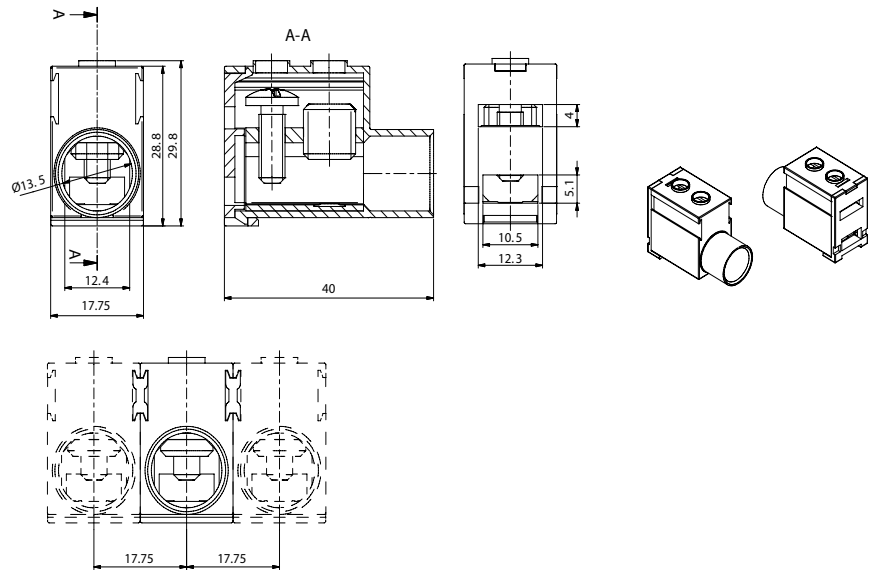

Attention! Z-EK/35/UL supply terminals may only be installed per the illustration below.

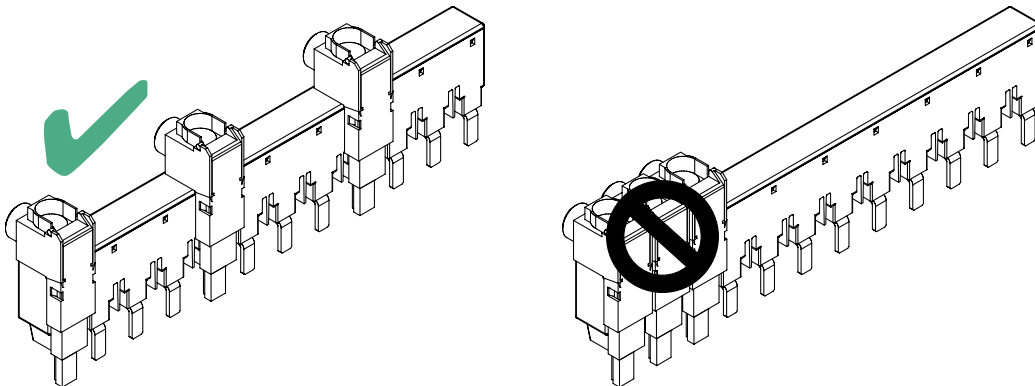

Lockout Attachment

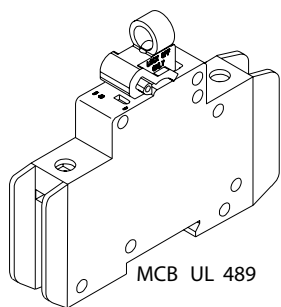
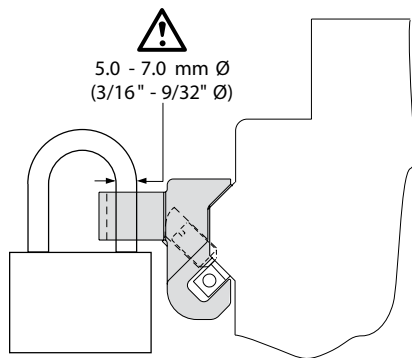
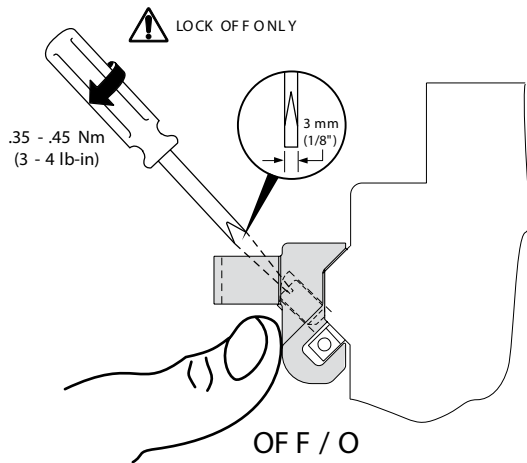

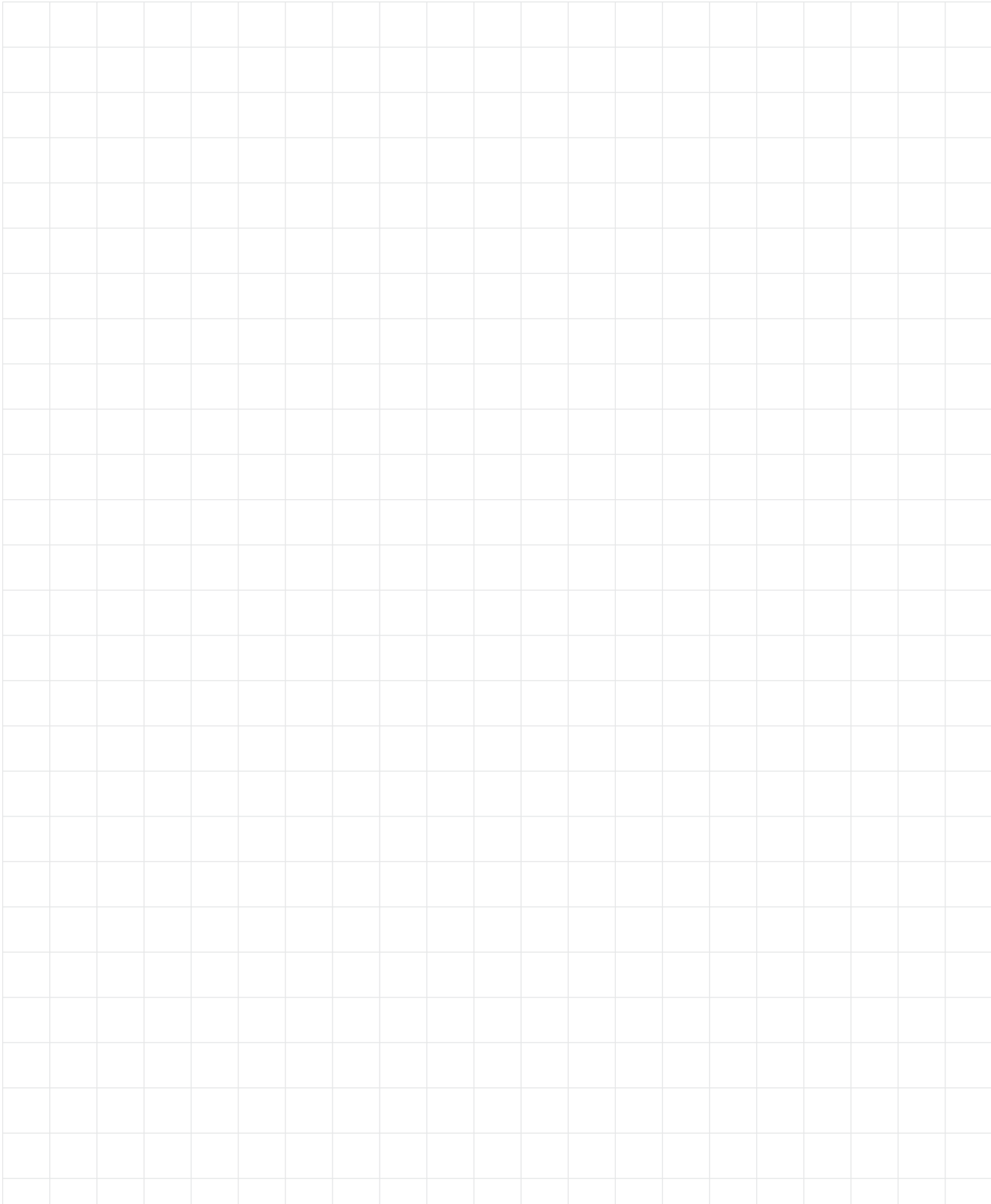

NEW >>

series FAZ supplementary protectors

Supplementary protection up to 10kA



See page 43 about...

Applying

FAZ

in North America

- > **Supplementary protector per UL 1077 / CSA 22.2 No. 235**
- > **Current limiting device**
- > **Very broad product range**
- > **Worldwide approvals**

Moeller's FAZ line of miniature circuit breakers includes a broad range of devices defined as "supplementary protectors." These breakers comply with UL 1077 and CSA 22.2 No. 235 regulations defining supplementary over-current protection. In these applications, branch circuit protection is not required, or is provided by a separate device like a fuse or molded case circuit breaker.

FAZ Supplementary Protectors are typically used for control circuits, lighting, business equipment, appliances and a range of other applications where "closer" protection is desired than that offered by a branch circuit protection device.

Extensive product range

Moeller Supplementary Protectors are available in one, two and three pole configurations and up to 17 different current ratings from 0.5A to 63A. One pole plus neutral, and three-pole plus neutral devices are also available. Six different trip characteristics including B, C, D, K, S and Z curves give you the ability to configure the exact protection scheme you require. Devices can be used in applications up to 480V AC and 48V DC with short circuit ratings up to 10kA.

Straightforward installation

All breakers mount on a standard 35mm DIN-rail. Each device has box terminals that accept multiple conductors. Bus Connectors and Feeder Terminals facilitate mounting and wiring of multiple miniature circuit breaker arrays in control panel assemblies. Power to the circuit breakers can also be fed from the line or load side.

Standard features enhance safety

As with most products from Moeller, FAZ breaker terminals provide finger and back-of-hand protection to guard against accidental contact with live parts.

A color-coded red/green indicator provides immediate visual indication of device status (green for OFF, red for ON) and isolation function.

All FAZ breakers also incorporate a "trip-free" mechanism. This prevents the trip function from being defeated by holding the operator in the ON position.

Worldwide acceptance

FAZ Supplementary Protectors are UL Recognized for use in the United States in accordance with NFPA 70 (NEC). The devices comply with UL 1077 and CSA 22.2 No.235, meeting the requirements for supplementary protectors. These devices also comply with IEC 60898 and are CE marked.

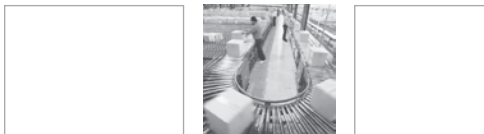



Six tripping curves to choose

Moeller FAZ Supplementary Protectors are available with six different tripping characteristics, including Type B, C, D, K, S and Z. Definitions for each trip curve are contained on the ordering pages and can be used to determine the optimal characteristic for your application. For example, low level short-circuit faults in control wiring, such as PLCs, are best protected by devices with Type B trip characteristics (3 to 5 X continuous rating of the device (I_n)).

Even though not required by NEC or CEC for Supplementary Protectors, Moeller's FAZ devices are current limiting, which means they interrupt fault currents within one half cycle. Current limiting devices offer superior protection by reducing peak let-through current and energy.

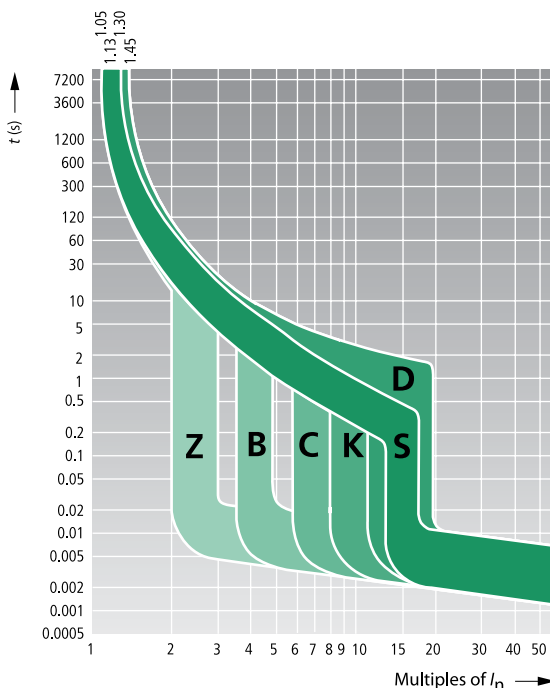

This graph shows trip-time versus over-current for all FAZ Supplementary Protectors.

Discover these advanced features

Available in over 400 configurations including B, C, D, K, S and D trip curves

Breakers install on standard DIN-rail

Available in one, two and three pole models; one and three pole plus neutral also available

Color coded indicator provides breaker status for easy troubleshooting

Complete bus bar system available for quickly installing breaker arrays in panel assemblies



Captive posidrive terminal screws with finger and back-of-hand protection (IP20)

Short circuit rating to 10kA (@277V AC and 480Y/277V AC for multi-pole to 40A)

Trip-free design; breaker cannot be defeated by holding the handle in the ON position

Box terminals accept #16 to #4 wire (1.5 to 25mm²)

Breaker information printed on the front of the device for quick identification

Trip Characteristic B

- > Designed for resistive or slightly inductive loads.
- > Response time of instantaneous trip: $3 - 5 \times I_n$ current rating
- > UL Recognized and CSA Certified as Supplementary Protectors
- > For international and domestic use (conform to IEC / EN60898)

Type B Characteristics

Suitable for applications where protection against low level short circuit faults in control wiring is desired. Instantaneous trip is 3 to 5 x continuous rating of device (I_n). Applications include PLC wiring, business equipment, lighting, appliances and some motors. Low magnetic trip point.

Trip Characteristic B – Designed for resistive or slightly inductive loads ¹

Rated Current I_n (A)	1 pole		2 poles		3 poles		4 poles	
	Type	Price	Type	Price	Type	Price	Type	Price
6	FAZ-B6/1	See green pages	FAZ-B6/2	See green pages	FAZ-B6/3	See green pages	FAZ-B6/4	See green pages
8	FAZ-B8/1		FAZ-B8/2		FAZ-B8/3		FAZ-B8/4	
10	FAZ-B10/1		FAZ-B10/2		FAZ-B10/3		FAZ-B10/4	
12	FAZ-B12/1		FAZ-B12/2		FAZ-B12/3		FAZ-B12/4	
13	FAZ-B13/1		FAZ-B13/2		FAZ-B13/3		FAZ-B13/4	
15	FAZ-B15/1		FAZ-B15/2		FAZ-B15/3		FAZ-B15/4	
16	FAZ-B16/1		FAZ-B16/2		FAZ-B16/3		FAZ-B16/4	
20	FAZ-B20/1		FAZ-B20/2		FAZ-B20/3		FAZ-B20/4	
25	FAZ-B25/1		FAZ-B25/2		FAZ-B25/3		FAZ-B25/4	
32	FAZ-B32/1		FAZ-B32/2		FAZ-B32/3		FAZ-B32/4	
40	FAZ-B40/1		FAZ-B40/2		FAZ-B40/3		FAZ-B40/4	
50	FAZ-B50/1		FAZ-B50/2		FAZ-B50/3		FAZ-B50/3	
63	FAZ-B63/1		FAZ-B63/2		FAZ-B63/3		FAZ-B63/3	

¹ In North America, these switches are UL recognized and CSA certified as Supplementary Protection devices. Per the intent of NEC (National Electrical Code), article 240, and CEC (Canadian Electrical Code), part 1 C22.1, supplementary breakers cannot be used as a substitute for the branch circuit protective device. They can be used to provide over-current protection within an appliance or other electrical equipment where branch circuit over-current protection is already provided, or is not required. See FAZ Branch Circuit Breakers in this catalog.

See Trip Curve chart on opposite page

- > Designed for resistive or slightly inductive loads.
- > Response time of instantaneous trip: $3 - 5 \times I_n$ current rating
- > UL Recognized and CSA Certified as Supplementary Protectors
- > For international and domestic use (conform to IEC / EN60898)

Type B Characteristics

Suitable for applications where protection against low level short circuit faults in control wiring is desired. Instantaneous trip is 3 to 5 x continuous rating of device (I_n). Applications include PLC wiring, business equipment, lighting, appliances and some motors. Low magnetic trip point.

Trip Characteristic B – Designed for resistive or slightly inductive loads ①

Rated Current I_n (A)	1 pole + Neutral		3 poles + Neutral	
	Type	Price	Type	Price
6	FAZ-B6/1N	See green pages	FAZ-B6/3N	See green pages
8	FAZ-B8/1N		FAZ-B8/3N	
10	FAZ-B10/1N		FAZ-B10/3N	
12	FAZ-B12/1N		FAZ-B12/3N	
13	FAZ-B13/1N		FAZ-B13/3N	
15	FAZ-B15/1N		FAZ-B15/3N	
16	FAZ-B16/1N		FAZ-B16/3N	
20	FAZ-B20/1N		FAZ-B20/3N	
25	FAZ-B25/1N		FAZ-B25/3N	
32	FAZ-B32/1N		FAZ-B32/3N	
40	FAZ-B40/1N		FAZ-B40/3N	
50	FAZ-B50/1N		FAZ-B50/3N	
63	FAZ-B63/1N		FAZ-B63/3N	

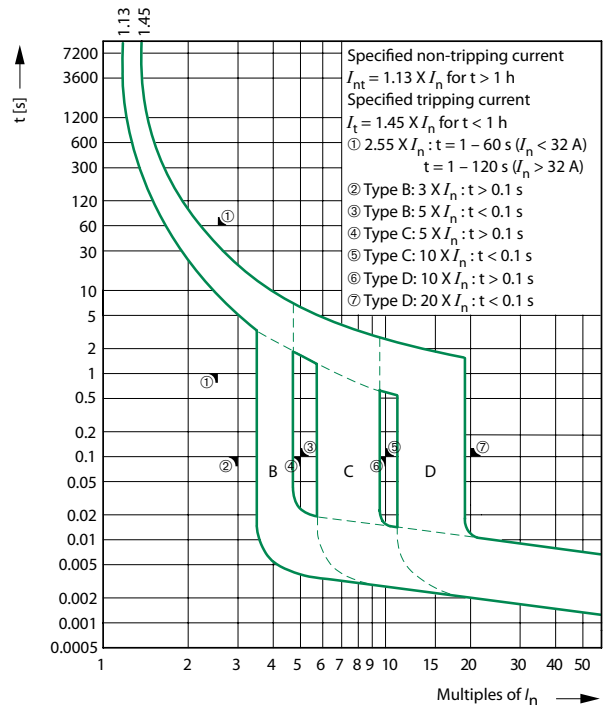

① In North America, these switches are UL recognized and CSA certified as Supplementary Protection devices. Per the intent of NEC (National Electrical Code), article 240, and CEC (Canadian Electrical Code), part 1 C22.1, supplementary breakers cannot be used as a substitute for the branch circuit protective device. They can be used to provide over-current protection within an appliance or other electrical equipment where branch circuit over-current protection is already provided, or is not required. See FAZ Branch Circuit Breakers in this catalog.

Trip Characteristic C

- > Designed for inductive loads.
- > Response time of instantaneous trip: $5 - 10 \times I_n$ current rating
- > UL Recognized and CSA Certified as Supplementary Protectors
- > For international and domestic use (conform to IEC / EN60898)

Type C Characteristics

Suitable for applications where medium levels of inrush current are expected. Instantaneous trip is 5 to 10 x rating of device (I_n). Applications include small transformers, lighting, pilot devices, control circuits, and coils. Medium magnetic trip point.

Trip Characteristic C – Designed for inductive loads ¹

Rated Current I_n (A)	1 pole		2 poles		3 poles		4 poles	
	Type	Price	Type	Price	Type	Price	Type	Price
0.5	FAZ-C0,5/1	See green pages	FAZ-C0,5/2	See green pages	FAZ-C0,5/3	See green pages	FAZ-C0,5/4	See green pages
1	FAZ-C1/1		FAZ-C1/2		FAZ-C1/3		FAZ-C1/4	
1.6	FAZ-C1,6/1		FAZ-C1,6/2		FAZ-C1,6/3		FAZ-C1,6/4	
2	FAZ-C2/1		FAZ-C2/2		FAZ-C2/3		FAZ-C2/4	
3	FAZ-C3/1		FAZ-C3/2		FAZ-C3/3		FAZ-C3/4	
4	FAZ-C4/1		FAZ-C4/2		FAZ-C4/3		FAZ-C4/4	
6	FAZ-C6/1		FAZ-C6/2		FAZ-C6/3		FAZ-C6/4	
8	FAZ-C8/1		FAZ-C8/2		FAZ-C8/3		FAZ-C8/4	
10	FAZ-C10/1		FAZ-C10/2		FAZ-C10/3		FAZ-C10/4	
13	FAZ-C13/1		FAZ-C13/2		FAZ-C13/3		FAZ-C13/4	
16	FAZ-C16/1		FAZ-C16/2		FAZ-C16/3		FAZ-C16/4	
20	FAZ-C20/1		FAZ-C20/2		FAZ-C20/3		FAZ-C20/4	
25	FAZ-C25/1		FAZ-C25/2		FAZ-C25/3		FAZ-C25/4	
32	FAZ-C32/1		FAZ-C32/2		FAZ-C32/3		FAZ-C32/4	
40	FAZ-C40/1		FAZ-C40/2		FAZ-C40/3		FAZ-C40/4	
50	FAZ-C50/1		FAZ-C50/2		FAZ-C50/3		FAZ-C50/4	
63	FAZ-C63/1		FAZ-C63/2		FAZ-C63/3		FAZ-C63/4	

¹ In North America, these switches are UL recognized and CSA certified as Supplementary Protection devices. Per the intent of NEC (National Electrical Code), article 240, and CEC (Canadian Electrical Code), part 1 C22.1, supplementary breakers cannot be used as a substitute for the branch circuit protective device. They can be used to provide over-current protection within an appliance or other electrical equipment where branch circuit over-current protection is already provided, or is not required. See FAZ Branch Circuit Breakers in this catalog.

See Trip Curve chart on opposite page

- > Designed for inductive loads.
- > Response time of instantaneous trip: 5 – 10 x I_n current rating
- > UL Recognized and CSA Certified as Supplementary Protectors
- > For international and domestic use (conform to IEC / EN60898)

Type C Characteristics

Suitable for applications where medium levels of inrush current are expected. Instantaneous trip is 5 to 10 x rating of device (I_n). Applications include small transformers, lighting, pilot devices, control circuits, and coils. Medium magnetic trip point.

Trip Characteristic C – Designed for inductive loads ①

Rated Current I_n (A)	1 pole + Neutral		3 poles + Neutral	
	Type	Price	Type	Price
0.5	FAZ-C0,5/1N	See green pages	FAZ-C0,5/3N	See green pages
1	FAZ-C1/1N		FAZ-C1/3N	
1.6	FAZ-C1,6/1N		FAZ-C1,6/3N	
2	FAZ-C2/1N		FAZ-C2/3N	
3	FAZ-C3/1N		FAZ-C3/3N	
4	FAZ-C4/1N		FAZ-C4/3N	
6	FAZ-C6/1N		FAZ-C6/3N	
8	FAZ-C8/1N		FAZ-C8/3N	
10	FAZ-C10/1N		FAZ-C10/3N	
13	FAZ-C13/1N		FAZ-C13/3N	
16	FAZ-C16/1N		FAZ-C16/3N	
20	FAZ-C20/1N		FAZ-C20/3N	
25	FAZ-C25/1N		FAZ-C25/3N	
32	FAZ-C32/1N		FAZ-C32/3N	
40	FAZ-C40/1N		FAZ-C40/3N	
50	FAZ-C50/1N		FAZ-C50/3N	
63	FAZ-C63/1N	FAZ-C63/3N		

① In North America, these switches are UL recognized and CSA certified as Supplementary Protection devices. Per the intent of NEC (National Electrical Code), article 240, and CEC (Canadian Electrical Code), part 1 C22.1, supplementary breakers cannot be used as a substitute for the branch circuit protective device. They can be used to provide over-current protection within an appliance or other electrical equipment where branch circuit over-current protection is already provided, or is not required. See FAZ Branch Circuit Breakers in this catalog.

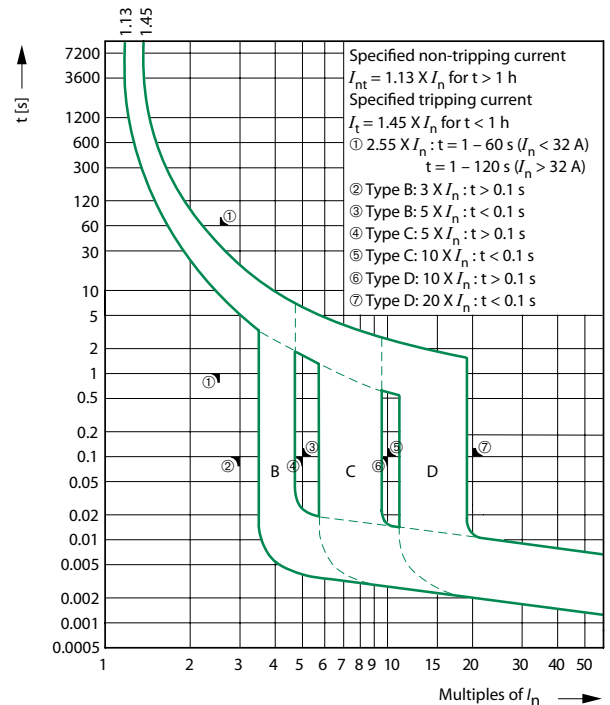

Trip Characteristic D

- > Designed for highly inductive loads.
- > Response time of instantaneous trip: $10 - 20 \times I_n$ current rating
- > UL Recognized and CSA Certified as Supplementary Protectors
- > For international and domestic use (conform to IEC / EN60898)

Type D Characteristics

Suitable for applications where high levels of inrush current are expected. Instantaneous trip is 10 to 20 x rating of device (I_n). The high magnetic trip point prevents nuisance tripping in high inductive applications such as motors, transformers, and power supplies.

Trip Characteristic D – Designed for highly inductive loads ¹

Rated Current I_n (A)	1 pole		2 poles		3 poles		4 poles	
	Type	Price	Type	Price	Type	Price	Type	Price
6	FAZ-D6/1	See green pages	FAZ-D6/2	See green pages	FAZ-D6/3	See green pages	FAZ-D6/4	See green pages
8	FAZ-D8/1		FAZ-D8/2		FAZ-D8/3		FAZ-D8/4	
10	FAZ-D10/1		FAZ-D10/2		FAZ-D10/3		FAZ-D10/4	
13	FAZ-D13/1		FAZ-D13/2		FAZ-D13/3		FAZ-D13/4	
16	FAZ-D16/1		FAZ-D16/2		FAZ-D16/3		FAZ-D16/4	
20	FAZ-D20/1		FAZ-D20/2		FAZ-D20/3		FAZ-D20/4	
25	FAZ-D25/1		FAZ-D25/2		FAZ-D25/3		FAZ-D25/4	
32	FAZ-D32/1		FAZ-D32/2		FAZ-D32/3		FAZ-D32/4	
40	FAZ-D40/1	FAZ-D40/2	FAZ-D40/3	FAZ-D40/4				

¹ In North America, these switches are UL recognized and CSA certified as Supplementary Protection devices. Per the intent of NEC (National Electrical Code), article 240, and CEC (Canadian Electrical Code), part 1 C22.1, supplementary breakers cannot be used as a substitute for the branch circuit protective device. They can be used to provide over-current protection within an appliance or other electrical equipment where branch circuit over-current protection is already provided, or is not required. See FAZ Branch Circuit Breakers in this catalog.

See Trip Curve chart on opposite page

- > Designed for highly inductive loads.
- > Response time of instantaneous trip: $10 - 20 \times I_n$ current rating
- > UL Recognized and CSA Certified as Supplementary Protectors
- > For international and domestic use (conform to IEC / EN60898)

Type D Characteristics

Suitable for applications where high levels of inrush current are expected. Instantaneous trip is 10 to 20 x rating of device (I_n). The high magnetic trip point prevents nuisance tripping in high inductive applications such as motors, transformers, and power supplies.

Trip Characteristic D – Designed for highly inductive loads ①

Rated Current I_n (A)	3 poles + Neutral	
	Type	Price
6	FAZ-D6/3N	See green pages
8	FAZ-D8/3N	
10	FAZ-D10/3N	
13	FAZ-D13/3N	
16	FAZ-D16/3N	
20	FAZ-D20/3N	
25	FAZ-D25/3N	
32	FAZ-D32/3N	
40	FAZ-D40/3N	

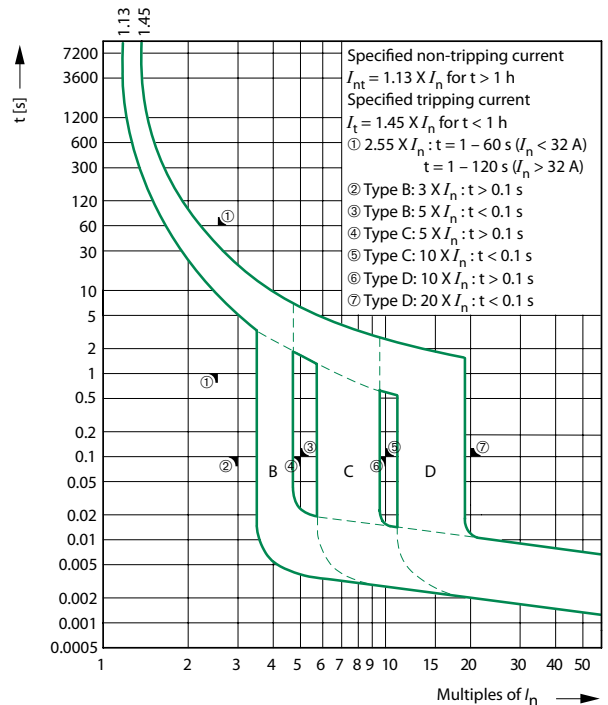

① In North America, these switches are UL recognized and CSA certified as Supplementary Protection devices. Per the intent of NEC (National Electrical Code), article 240, and CEC (Canadian Electrical Code), part 1 C22.1, supplementary breakers cannot be used as a substitute for the branch circuit protective device. They can be used to provide over-current protection within an appliance or other electrical equipment where branch circuit over-current protection is already provided, or is not required. See FAZ Branch Circuit Breakers in this catalog.

Trip Characteristic K

- > Designed for motors, transformers and upstream electronics.
- > Response time of instantaneous trip: $8 - 12 \times I_n$ current rating
- > UL Recognized and CSA Certified as Supplementary Protectors
- > For international and domestic use (conform to IEC / EN60898)

Type K Characteristics

Suitable for applications where high levels of inrush current are expected. Instantaneous trip is 8 to 12 x continuous rating of device (I_n). The high magnetic trip point is ideal for motors and transformers. The narrow range (compared with the type D curve) makes it ideal for applications where nuisance tripping is not an issue.

Trip Characteristic K – Designed for motors, transformers and upstream electronics ①

Rated Current I_n (A)	1 pole		2 poles		3 poles		4 poles	
	Type	Price	Type	Price	Type	Price	Type	Price
0.5	FAZ-K0,5/1	See green pages	FAZ-K0,5/2	See green pages	FAZ-K0,5/3	See green pages	FAZ-K0,5/4	See green pages
1	FAZ-K1/1		FAZ-K1/2		FAZ-K1/3		FAZ-K1/4	
1.6	FAZ-K1,6/1		FAZ-K1,6/2		FAZ-K1,6/3		FAZ-K1,6/4	
2	FAZ-K2/1		FAZ-K2/2		FAZ-K2/3		FAZ-K2/4	
3	FAZ-K3/1		FAZ-K3/2		FAZ-K3/3		FAZ-K3/4	
4	FAZ-K4/1		FAZ-K4/2		FAZ-K4/3		FAZ-K4/4	
6	FAZ-K6/1		FAZ-K6/2		FAZ-K6/3		FAZ-K6/4	
8	FAZ-K8/1		FAZ-K8/2		FAZ-K8/3		FAZ-K8/4	
10	FAZ-K10/1		FAZ-K10/2		FAZ-K10/3		FAZ-K10/4	
13	FAZ-K13/1		FAZ-K13/2		FAZ-K13/3		FAZ-K13/4	
16	FAZ-K16/1		FAZ-K16/2		FAZ-K16/3		FAZ-K16/4	
20	FAZ-K20/1		FAZ-K20/2		FAZ-K20/3		FAZ-K20/4	
25	FAZ-K25/1		FAZ-K25/2		FAZ-K25/3		FAZ-K25/4	
32	FAZ-K32/1		FAZ-K32/2		FAZ-K32/3		FAZ-K32/4	
40	FAZ-K40/1		FAZ-K40/2		FAZ-K40/3		FAZ-K40/4	
50	FAZ-K50/1		FAZ-K50/2		FAZ-K50/3		FAZ-K50/4	
63	FAZ-K63/1	FAZ-K63/2	FAZ-K63/3	FAZ-K63/4				

Special Order

These breakers are available by special order only. Contact your Moeller representative for more information.

① In North America, these switches are UL recognized and CSA certified as Supplementary Protection devices. Per the intent of NEC (National Electrical Code), article 240, and CEC (Canadian Electrical Code), part 1 C22.1, supplementary breakers cannot be used as a substitute for the branch circuit protective device. They can be used to provide over-current protection within an appliance or other electrical equipment where branch circuit over-current protection is already provided, or is not required. See FAZ Branch Circuit Breakers in this catalog.

See Trip Curve chart on opposite page

- > Designed for motors, transformers and upstream electronics.
- > Response time of instantaneous trip: $8 - 12 \times I_n$ current rating
- > UL Recognized and CSA Certified as Supplementary Protectors
- > For international and domestic use (conform to IEC / EN60898)

Type K Characteristics

Suitable for applications where high levels of inrush current are expected. Instantaneous trip is 8 to 12 x continuous rating of device (I_n). The high magnetic trip point is ideal for motors and transformers. The narrow range (compared with the type D curve) makes it ideal for applications where nuisance tripping is not an issue.

Trip Characteristic K – Designed for motors, transformers and upstream electronics ①

Rated Current I_n (A)	3 poles + Neutral	
	Type	Price
0.5	FAZ-K0,5/3N	See green pages
1	FAZ-K1/3N	
1.6	FAZ-K1,6/3N	
2	FAZ-K2/3N	
3	FAZ-K3/3N	
4	FAZ-K4/3N	
6	FAZ-K6/3N	
8	FAZ-K8/3N	
10	FAZ-K10/3N	
13	FAZ-K13/3N	
16	FAZ-K16/3N	
20	FAZ-K20/3N	
25	FAZ-K25/3N	
32	FAZ-K32/3N	
40	FAZ-K40/3N	
50	FAZ-K50/3N	
63	FAZ-K63/3N	

Special Order
These breakers are available by special order only. Contact your Moeller representative for more information.

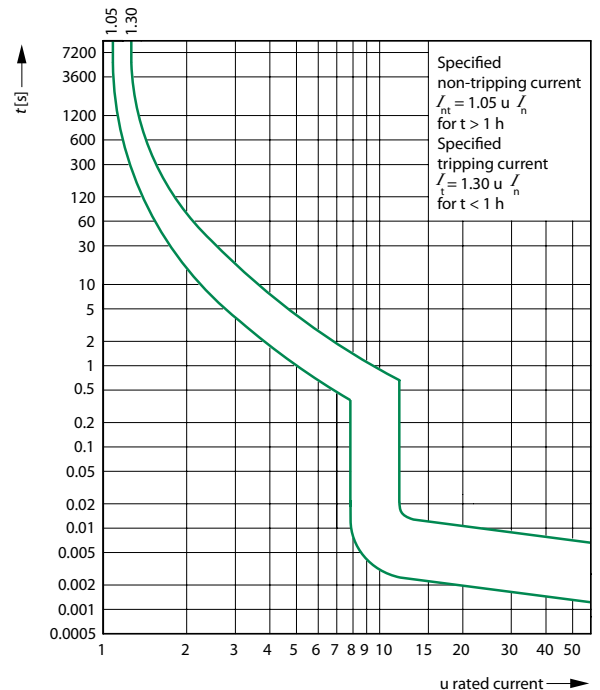

① In North America, these switches are UL recognized and CSA certified as Supplementary Protection devices. Per the intent of NEC (National Electrical Code), article 240, and CEC (Canadian Electrical Code), part 1 C22.1, supplementary breakers cannot be used as a substitute for the branch circuit protective device. They can be used to provide over-current protection within an appliance or other electrical equipment where branch circuit over-current protection is already provided, or is not required. See FAZ Branch Circuit Breakers in this catalog.

Trip Characteristic Z

- Designed for protection of electronic devices.
- Response time of instantaneous trip: $2 - 3 \times I_n$ current rating
- UL Recognized and CSA Certified as Supplementary Protectors
- For international and domestic use (conform to IEC / EN60898)

Type Z Characteristics

Suitable for applications where semiconductors and other components that fail open are used. Instantaneous trip is 2 to 3 x continuous rating of device (I_n). The short thermal delay and low magnetic trip point are ideal for applications where devices and components have low surge and short circuit tolerances.

Trip Characteristic Z – Designed for protection of electronic devices ①

Rated Current I_n (A)	1 pole		2 poles		3 poles		4 poles	
	Type	Price	Type	Price	Type	Price	Type	Price
0.5	FAZ-Z0,5/1	See green pages	FAZ-Z0,5/2	See green pages	FAZ-Z0,5/3	See green pages	FAZ-Z0,5/4	See green pages
1	FAZ-Z1/1		FAZ-Z1/2		FAZ-Z1/3		FAZ-Z1/4	
1.6	FAZ-Z1,6/1		FAZ-Z1,6/2		FAZ-Z1,6/3		FAZ-Z1,6/4	
2	FAZ-Z2/1		FAZ-Z2/2		FAZ-Z2/3		FAZ-Z2/4	
3	FAZ-Z3/1		FAZ-Z3/2		FAZ-Z3/3		FAZ-Z3/4	
4	FAZ-Z4/1		FAZ-Z4/2		FAZ-Z4/3		FAZ-Z4/4	
6	FAZ-Z6/1		FAZ-Z6/2		FAZ-Z6/3		FAZ-Z6/4	
8	FAZ-Z8/1		FAZ-Z8/2		FAZ-Z8/3		FAZ-Z8/4	
10	FAZ-Z10/1		FAZ-Z10/2		FAZ-Z10/3		FAZ-Z10/4	
16	FAZ-Z16/1		FAZ-Z16/2		FAZ-Z16/3		FAZ-Z16/4	
20	FAZ-Z20/1		FAZ-Z20/2		FAZ-Z20/3		FAZ-Z20/4	
25	FAZ-Z25/1		FAZ-Z25/2		FAZ-Z25/3		FAZ-Z25/4	
32	FAZ-Z32/1		FAZ-Z32/2		FAZ-Z32/3		FAZ-Z32/4	
40	FAZ-Z40/1		FAZ-Z40/2		FAZ-Z40/3		FAZ-Z40/4	
50	FAZ-Z50/1		FAZ-Z50/2		FAZ-Z50/3		FAZ-Z50/4	
63	FAZ-Z63/1		FAZ-Z63/2		FAZ-Z63/3		FAZ-Z63/4	

Special Order

These breakers are available by special order only. Contact your Moeller representative for more information.

① In North America, these switches are UL recognized and CSA certified as Supplementary Protection devices. Per the intent of NEC (National Electrical Code), article 240, and CEC (Canadian Electrical Code), part 1 C22.1, supplementary breakers cannot be used as a substitute for the branch circuit protective device. They can be used to provide over-current protection within an appliance or other electrical equipment where branch circuit over-current protection is already provided, or is not required. See FAZ Branch Circuit Breakers in this catalog.

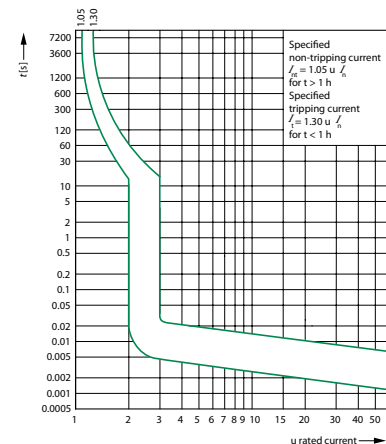

- > Designed for control circuits with high inrush
- > Response time of instantaneous trip: $13 - 17 \times I_n$ current rating
- > UL Recognized and CSA Certified as Supplementary Protectors
- > For international and domestic use (conform to IEC / EN60898)

Type S Characteristics

Suitable for applications with highly inductive loads, especially in control circuits with coils and light filaments. Instantaneous response between 13 to 17 x rating of device (I_n).

Trip Characteristic S – Designed for control circuits with high inrush ①

Rated Current I_n (A)	1 pole		2 poles	
	Type	Price	Type	Price
1	FAZ-S1/1	See green pages	FAZ-S1/2	See green pages
2	FAZ-S2/1		FAZ-S2/2	
3	FAZ-S3/1		FAZ-S3/2	
4	FAZ-S4/1		FAZ-S4/2	
6	FAZ-S6/1		FAZ-S6/2	
10	FAZ-S10/1		FAZ-S10/2	
16	FAZ-S16/1		FAZ-S16/2	
20	FAZ-S20/1		FAZ-S20/2	
25	FAZ-S25/1		FAZ-S25/2	
32	FAZ-S32/1		FAZ-S32/2	
40	FAZ-S40/1		FAZ-S40/2	

Special Order
 These breakers are available by special order only.
 Contact your Moeller representative for more information.

① In North America, these switches are UL recognized and CSA certified as Supplementary Protection devices. Per the intent of NEC (National Electrical Code), article 240, and CEC (Canadian Electrical Code), part 1 C22.1, supplementary breakers cannot be used as a substitute for the branch circuit protective device. They can be used to provide over-current protection within an appliance or other electrical equipment where branch circuit over-current protection is already provided, or is not required. See FAZ Branch Circuit Breakers in this catalog.

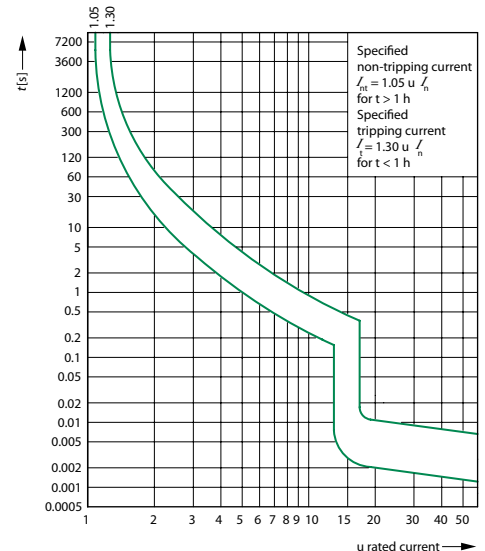

Auxiliary Contacts and Voltage Trips

Module	Circuit Diagram	Description	Rated Operational Voltage	Type	Price
		Standard auxiliary contact – 1 NO / 1 NC – Installs on left side of FAZ or Shunt Trip – Max. one per FAZ (1077) device – Switches when FAZ is tripped electrically or manually	230V AC	FAZ-XHI11	See green pages
	 Two-pole auxiliary mode Trip indicating mode	Selectable 2-pole Auxiliary Contact or Auxiliary/Trip-indicating contacts – Small selector screw changes mode – Two Form C (changeover) contacts – Installs on left side of FAZ or Shunt Trip – Aux. contacts switch when FAZ is tripped electrically or manually – Trip indicating contact switches only when FAZ is tripped electrically	230V AC	FAZ-XAM002	
		Undervoltage trip – Prevents FAZ from operating unless voltage is present – Installs on left side of FAZ – Includes test button	115V AC	FAZ-XUA(115VAC)	
			230V AC	FAZ-XUA(230VAC)	
			400V AC	FAZ-XUA(400VAC)	
		Shunt trip – Allows remote trip of FAZ – Installs on left side of FAZ	110–415V AC 110–230V DC	FAZ-XAA-C-12-110VAC	
			12 – 110V AC 12 – 60V DC	FAZ-XAA-C-110-415VAC	

Allowable combinations of accessories

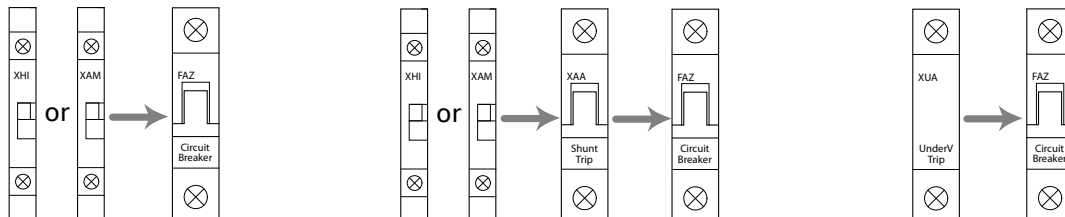

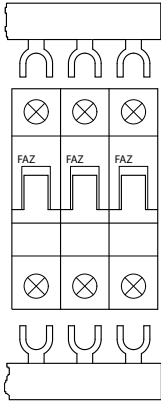
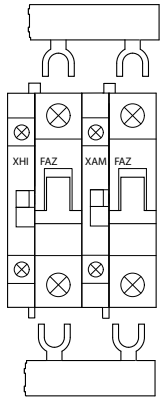

Bus Bar System ①

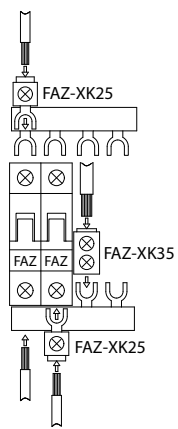

Description	Number of Poles per Device	Number of Terminals	Rated Operational Current (A) ①	Type	Price			
<p>For connecting FAZ Supplementary Protectors without auxiliary contacts. May be fed from line or load side.</p> 	1	2	80	EVG-16/1PHAS/2MODUL	See green pages			
		6		EVG-16/1PHAS/6MODUL				
		12		EVG-16/1PHAS/12MODUL				
	2	4		EVG-16/2PHAS/4MODUL				
		6		EVG-16/2PHAS/6MODUL				
		12		EVG-16/2PHAS/12MODUL				
	3	6		EVG-16/3PHAS/6MODUL				
		12		EVG-16/3PHAS/12MODUL				
	4	8		EVG-16/4PHAS/8MODUL				
		12		EVG-16/4PHAS/12MODUL				
	<p>For connecting FAZ Supplementary Protectors with auxiliary contacts. May be fed from line or load side.</p> 	1		2		80	EVG-16/1PHAS/2MODUL/HI	See green pages
				6			EVG-16/1PHAS/6MODUL/HI	
9			EVG-16/1PHAS/9MODUL/HI					
2		4	EVG-16/2PHAS/4MODUL/HI					
		6	EVG-16/2PHAS/6MODUL/HI					
		10	EVG-16/2PHAS/10MODUL/HI					
3		6	EVG-16/3PHAS/6MODUL/HI					
		12	EVG-16/3PHAS/12MODUL/HI					

① IEC rated only.

Incoming Supply Terminals ①

Accessories	Description	Installation	Type	Price
	Fork connector – Accommodates conductors up to 25 mm ² (~ AWG 4) – Finger-safe connection		FAZ-XK25	See green pages
	Bus connector – For conductors up to 35 mm ² (~ AWG 2) – Finger-safe connection to FAZ-XIS...		FAZ-XK35	

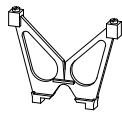
Protective Accessories

Accessories	Description	Type	Price
	Bus Bar Terminal Cover For covering unused terminals	FAZ-XBS	See green pages
	Bracket for securing the covers Two required per group of supplementary protectors	REG-BB	
	Padlock Hasp – Prevents reactivation of the device during maintenance – Holds one padlock	FAZ/FIP-XSV	

① IEC rated only.

Let-through energy I_2t

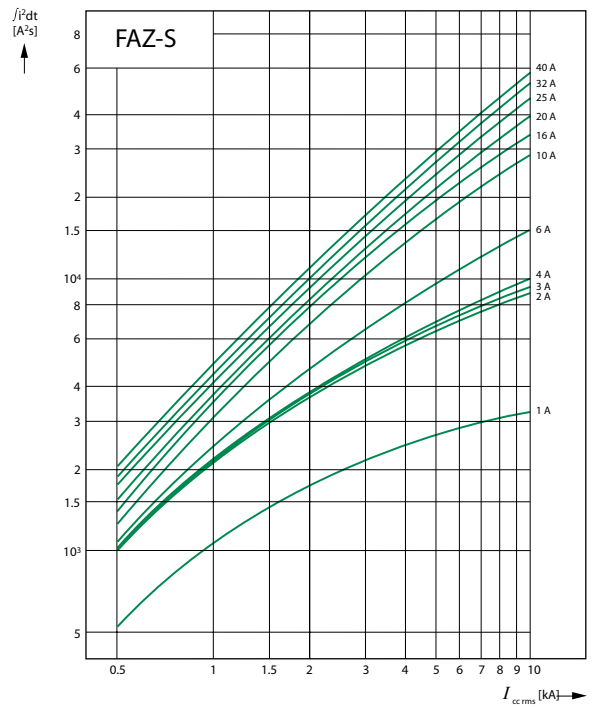
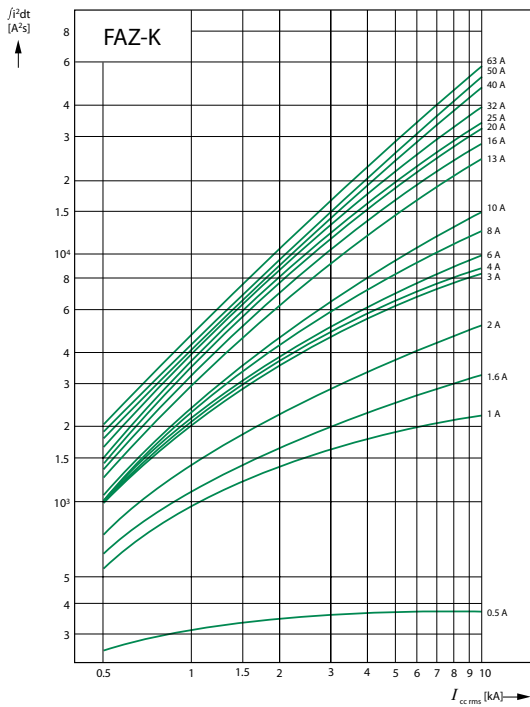
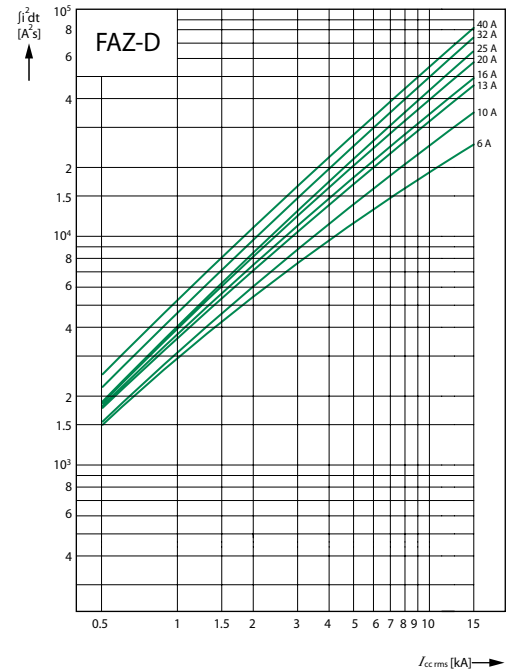
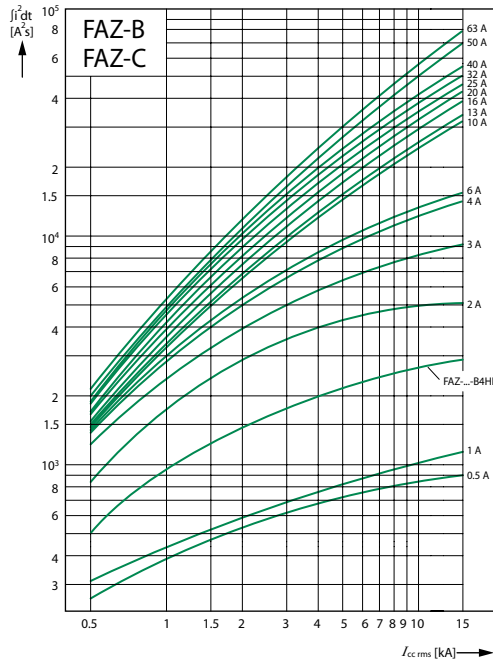

Let-through energy I_2t

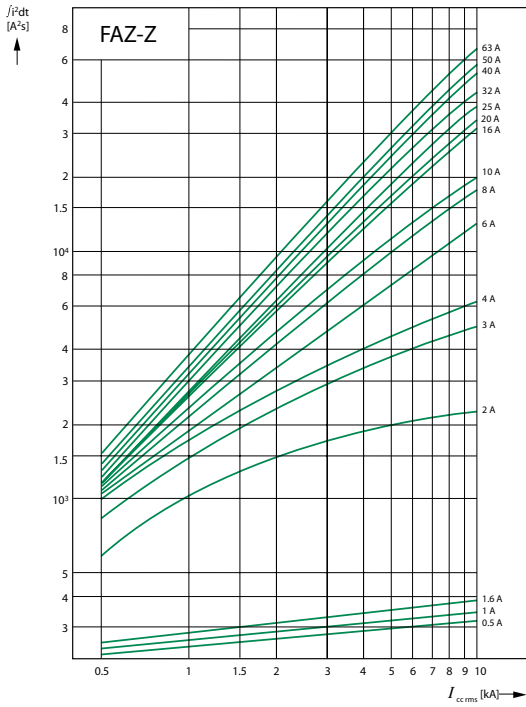

Let-through current I_D

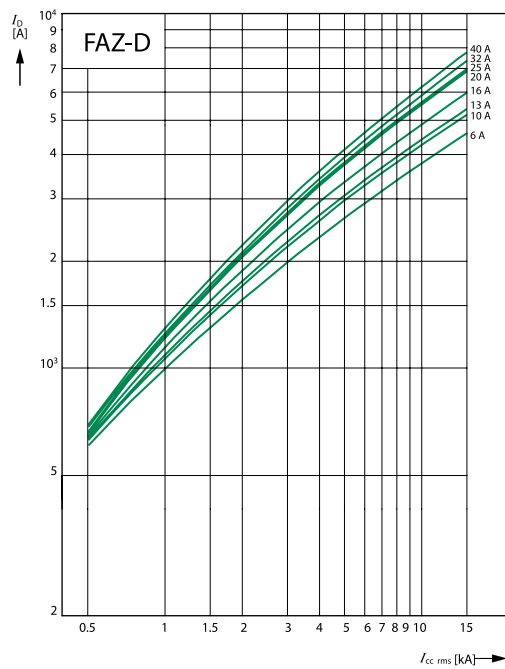
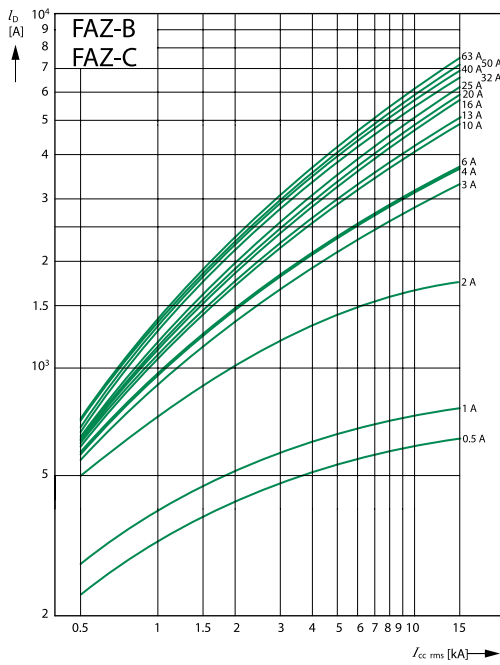

Let-through current I_D

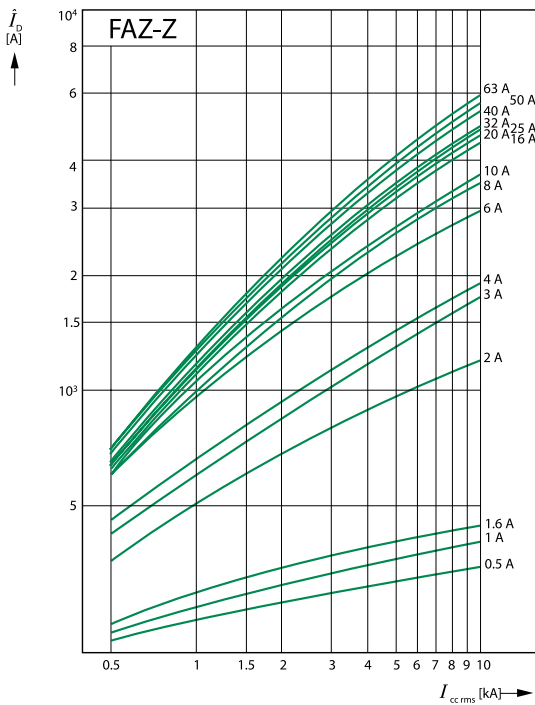
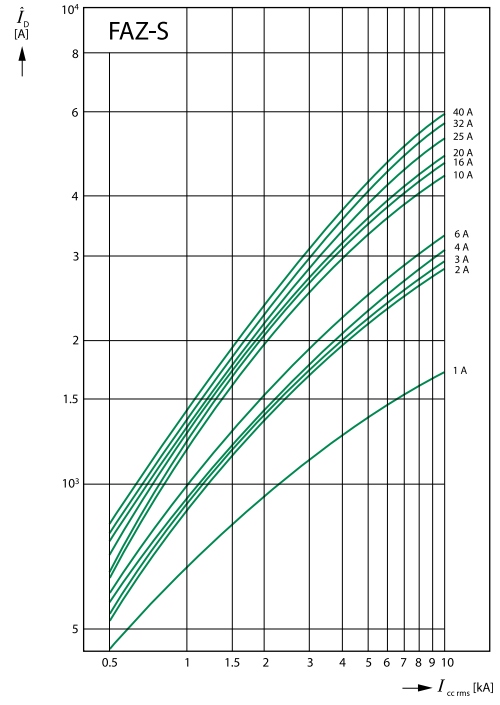
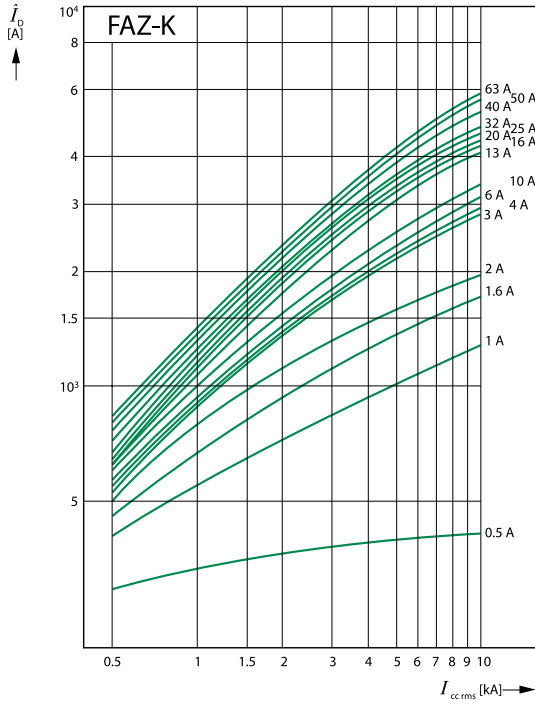

		B curve	C curve	D curve	K curve	S curve	Z curve
Electrical							
Approvals Standards		UR (UL 1077), CSA (CSA 22.2 No. 235), CE, VDE IEC/EN 60947-2					
Short Circuit Trip Response		$3 \times 5 I_n$	$5 \times 10 I_n$	$10 \times 20 I_n$	$8 \times 12 I_n$	$13 \times 17 I_n$	$2 \times 3 I_n$
Supplementary Protectors - UL / CSA							
Current Range	[A]	6...63	0.5...63	6...40	0.5...63	0.5...63	1...40
Maximum voltage ratings – UL / CSA							
1 pole & 1 pole + neutral	[V AC]	277	277	277	277	277	277
	[V DC]	48	48	48	48	48	48
2, 3, 4 pole & 3 pole + neutral	[V AC]	480Y/277	480Y/277	480Y/277	480Y/277	480Y/277	480Y/277
Thermal Tripping Characteristics							
Single Pole		$1.35 \times I_n @ 40^\circ\text{C}$					
Multi-pole		$1.45 \times I_n @ 40^\circ\text{C}$					
Short circuit ratings (at max. voltage)							
1 pole	[kA]	10 (5 for 40A device)				5 (10 @ 48V DC)	
1 pole + neutral	[kA]	10 (5 for 40A device)				5 (10 @ 48V DC)	
2, 3 & 4 pole	[kA]	10 (5 for 40A device)				5 (10 @ 48V DC)	
3 pole + neutral	[kA]	10 (5 for 40A device)				5 (10 @ 48V DC)	
2 poles in series	[kA]	10 @ 125V DC				10 @ 125V DC	
Miniature Circuit Breaker - IEC							
Current Range	[A]	6...40	0.5...40	6...25	0.5...40	0.5...40	1...16
Maximum voltage ratings – IEC							
1 pole & 1 pole + neutral	[V AC]	240	240	240	240	240	240
	[V DC]	48	48	48	48	48	48
2, 3, 4 pole & 3 pole + neutral	[V AC]	240/415	240/415	240/415	240/415	240/415	240/415
Thermal Tripping Characteristics							
Single Pole		$> 1 \text{ hour} @ 1.05 \times I_n$					
Multi-pole		$< 1 \text{ hour} @ 1.3 \times I_n$					
Interrupt ratings (at max. voltage)	[kA]	15	15	15	15	10	10
Operational switching capacity	[kA]	7.5					
Max. back-up fuse	[A gL/gG]	125					
Rated impulse withstand - U_{imp}	[V AC]	4000					
Rated insulation voltage - U_i	[V AC]	440					
Environmental / General							
Selectivity Class		3					
Lifespan	[ops.]	> 10000 (1 operation = ON/OFF)					
Shock (IEC 68-2-22)	[g]	10g - 120ms					
Operating Temperature Range	[°F]	23...+104 (-5...+40°C)					
Shipment & short term storage	[°F]	-40...+185 (-40...+85°C)					
Housing material		Nylon					
Mechanical							
Standard front dimension							
Device height	[mm]	80					
Terminal protection	[mm]	Finger- and back-of-hand proof to IEC 536					
Mounting width per pole	[mm]	17.7					
Mounting		IEC/EN 60715 top-hat rail					
Degree of protection		IP20					
Terminals top and bottom		Twin-purpose terminals					
Supply connection		Line or load side					
Terminal capacity	[mm ²]	1 x 25 (AWG 4...18)					
	[mm ²]	2 x 10 (AWG 8...18)					
Torque	[nm]	2.4					
Thickness of busbar material		0.8 – 2					
Mounting position	[mm]	As required					

Influence of the ambient temperature on the thermal tripping behavior

Corrected values of the rated current dependent on the ambient temperature

I_n [A]	Ambient Temperature T [°C]												
	-25	-20	-10	0	10	20	30	35	40	45	50	55	60
0.16	0.20	0.19	0.19	0.18	0.17	0.17	0.16	0.16	0.15	0.15	0.15	0.14	0.14
0.25	0.31	0.30	0.29	0.28	0.27	0.26	0.25	0.25	0.24	0.24	0.23	0.23	0.22
0.5	0.61	0.60	0.58	0.56	0.54	0.52	0.50	0.49	0.48	0.47	0.46	0.45	0.44
0.75	0.92	0.90	0.87	0.84	0.81	0.78	0.75	0.74	0.73	0.71	0.69	0.68	0.66
1	1.2	1.2	1.2	1.1	1.1	1.0	1.0	0.99	0.97	0.95	0.93	0.90	0.89
1.5	1.8	1.8	1.7	1.7	1.6	1.6	1.5	1.5	1.5	1.4	1.4	1.4	1.3
1.6	2.0	1.9	1.9	1.8	1.7	1.7	1.6	1.6	1.5	1.5	1.5	1.4	1.4
2	2.4	2.4	2.3	2.2	2.2	2.1	2.0	2.0	1.9	1.9	1.9	1.8	1.8
2.5	3.1	3.0	2.9	2.8	2.7	2.6	2.5	2.5	2.4	2.4	2.3	2.3	2.2
3	3.7	3.6	3.5	3.4	3.3	3.1	3.0	3.0	2.9	2.8	2.8	2.7	2.7
3.5	4.3	4.2	4.1	3.9	3.8	3.7	3.5	3.4	3.4	3.3	3.2	3.2	3.1
4	4.9	4.8	4.7	4.5	4.3	4.2	4.0	3.9	3.9	3.8	3.7	3.6	3.5
5	6.1	6.0	5.8	5.6	5.4	5.2	5.0	4.9	4.8	4.7	4.6	4.5	4.4
6	7.3	7.2	7.0	6.7	6.5	6.3	6.0	5.9	5.8	5.7	5.6	5.4	5.3
8	9.8	9.6	9.3	9.0	8.7	8.4	8.0	7.9	7.7	7.6	7.4	7.2	7.1
10	12	12	12	11	11	10	10	9.9	9.7	9.5	9.3	9.0	8.9
12	15	14	14	13	13	13	12	12	12	11	11	11	11
13	16	16	15	15	14	14	13	13	13	12	12	12	12
15	18	18	17	17	16	16	15	15	15	14	14	14	13
16	20	19	19	18	17	17	16	16	15	15	15	14	14
20	24	24	23	22	22	21	20	20	19	19	19	18	18
25	31	30	29	28	27	26	25	25	24	24	23	23	22
32	39	38	37	36	35	33	32	32	31	30	30	29	28
40	49	48	47	45	43	42	40	39	39	38	37	36	35
50	61	60	58	56	54	52	50	49	48	47	46	45	44
63	77	76	73	71	68	66	63	62	61	60	58	57	56

Load carrying capacity of adjoining miniature circuit-breakers

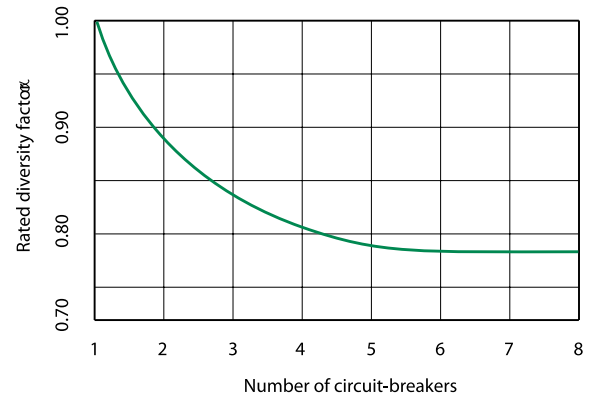

Influence of the mains frequency

Influence of the mains frequency on the tripping behavior I_{MA} of the instantaneous release

	Mains frequency f [Hz]						
	16 2/3	50	60	100	200	300	400
$I_{MA}(f)/I_{MA}(50 \text{ Hz})$ [%]	91	100	101	106	115	134	141

			FAZ-XHI11 Auxiliary FAZ-XAM002 Aux/Trip Indication	FAZ-XAA-C... Shunt Trip	FAZ-XUA... Undervoltage Trip
Electrical					
Contact function			1M + 1B 2 C/O	–	–
Rated operational voltage	Un	[V AC]	250	–	115 230 400
Voltage range		[V AC]		12 – 110 110 – 415	
		[V DC]	–	110 – 230 12 – 60	–
Closing threshold		[x U_n]	–	–	0.8
Tripping threshold		[x U_n]	–	–	0.5
Rated frequency	f	[Hz]	50/60	50/60	50/60
General use (UL / CSA)					
AC	230/240V AC	[A]	2 / 2	–	–
DC	110/120V DC	[A]	0.5 / 0.5	–	–
Pilot Duty			A600 / Q600	–	–
Conventional free air thermal current	I_{th}	[A]	4		
Rated operational current					
AC-13	I_e	[A]	3 (250 V AC)	–	–
AC-15	I_e	[A]	2 (250 V AC)	–	–
DC-13	I_e	[A]	0.5 (110 V DC)	–	–
Rated insulation voltage	U_i	[V AC]	250	–	–
Minimum operating voltage per contract	U_{min}	[V DC]	5	–	–
Rated impulse withstand voltage (1.2/50 μ)	U_{imp}	[kV]	2.5	–	–
Rated conditional short-circuit current with 6A back-up fuse	I_{sc}	[kA]	1	–	–
Max. admissible back-up fuse		[A gL]	4	–	–
Mechanical					
Standard front dimension		[mm]	45	45	45
Device height		[mm]	80	80	80
Mounting width		[mm]	8.8	17.6	17.8
Mounting			On MCB	IEC/EN 60715 top-hat rail	IEC/EN 60715 top-hat rail
Degree of protection					
Enclosed			IP40	IP40	IP40
Terminal protection					
Terminals			Protection against electric shock to IEC 536 Lift terminals	Protection against electric shock to IEC 536 Twin-purpose terminals	Protection against electric shock to IEC 536 Twin-purpose terminals
Terminal capacity					
Solid		[mm ²]	0.5 – 2.5	1 – 2.5	2 x (1 – 2.5)
Flexible		[mm ²]	0.5 – 2.5	1 – 2.5	2 x (1 – 2.5)
Tightening torque of terminal screws		[Nm]	0.8 – 1.0	2.4	0.8

Miniature circuit-breakers

FAZ

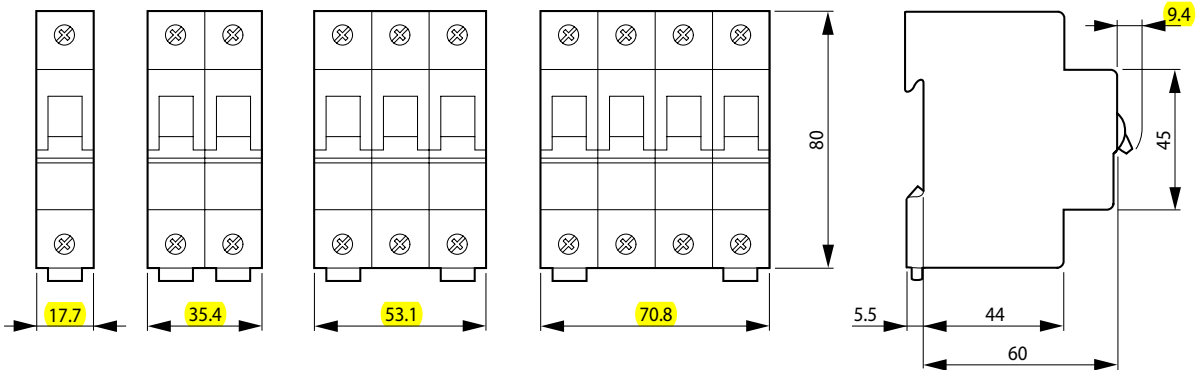

Auxiliary contacts

FAZ-XHI11

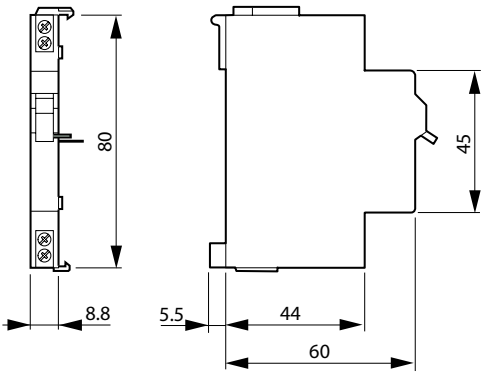

FAZ-XAM002

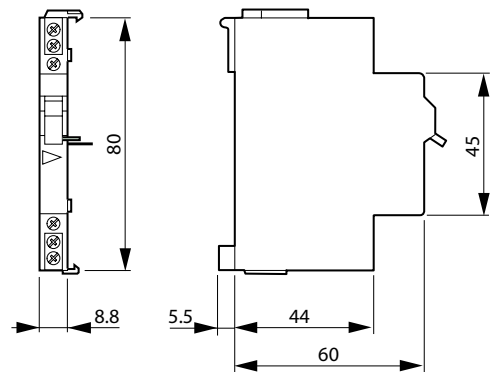

Shunt releases

FAZ-XAA

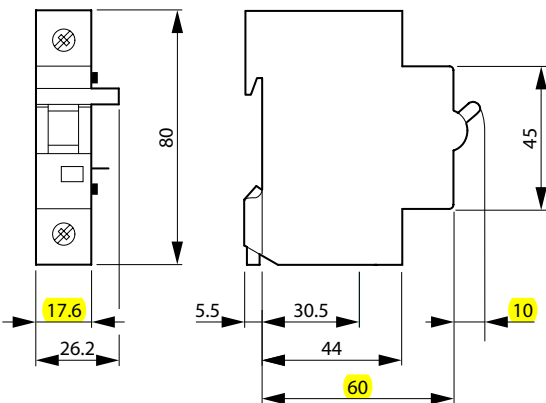

Undervoltage releases

FAZ-XUA

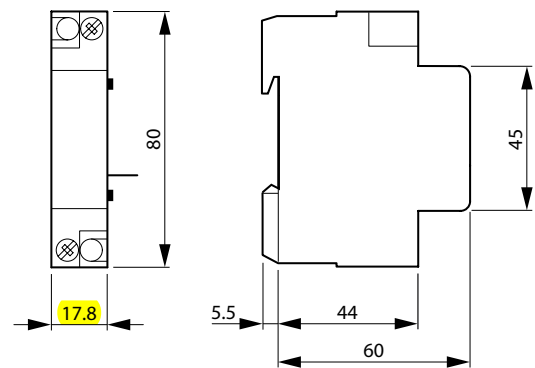

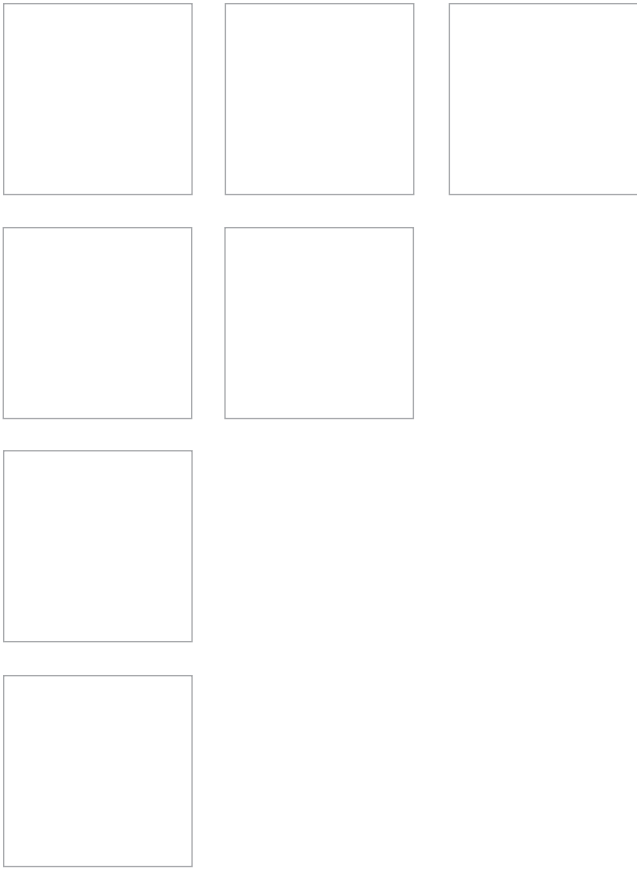

Applying branch circuit breakers and supplementary protectors in North America

Andre R. Fortin
Manager, Codes & Standards
Moeller Electric Inc.

Applying branch circuit breakers and supplementary protectors in North America



Introduction

Moeller offers two types of miniature circuit breakers for use in North America. The first version, FAZ-NA(RT), fully complies with the Molded Case Circuit Breaker standard UL 489 and the Canadian equivalent CSA 22.2 No. 5-02, which states that devices within that range can be applied legitimately as Feeder and Branch Circuit Protective devices per the US and Canadian electrical Codes.

A second version, FAZ, is recognized per UL 1077 and certified per CSA C22.2 No. 235 as a Supplementary Protector and can be fully utilized per the NEC and CEC Codes in that capacity. For international purposes, the entire FAZ family is CE marked and in full conformity with the applicable IEC standards for miniature circuit breakers, EN/IEC 60 898 and EN/IEC 60 947-2.

Both FAZ and FAZ-NA(RT) are offered in various ampere ranges and tripping characteristics. This paper will focus on the main technical aspects of the entire line and should assist in the proper selection and application of all versions.

Characteristics of IEC-style Miniature Circuit Breakers

Because Moeller's FAZ Miniature Circuit Breakers are IEC-style devices, it is important to understand their inherent characteristics before examining them in the context of UL / CSA requirements.

- IEC-style miniature circuit breakers are thermal-magnetic, inverse time protective devices, with both a fixed thermal and a fixed magnetic trip setting.
- They are toggle operated, and like all modern circuit breakers, feature a "trip-free" mechanism. This means that the tripping action works independently of the handle position for safety purposes.
- They all mount on a standard 35mm DIN-rail and share a common single pole width of 17.5 mm.
- Most comply with EN/IEC 60898 and EN/IEC 60947-2, which are the relevant international performance and testing standards for low voltage (<1000V) circuit breakers in Europe and the rest of the IEC world.
- Outside North America, they can be used in both residential and industrial applications as feeder and branch circuit protective devices.
- In North America, most European Miniature Circuit Breakers are only UL recognized and CSA certified as "Supplementary Protectors," meaning they cannot be utilized as feeder or branch circuit protective devices per the local electrical codes. This commonly restricts their use to applications where "closer" protection is desired than that offered by a branch circuit protection device.
- Some variations, like Moeller's new FAZ-NA(RT) line have been specially designed to meet UL and CSA requirements for Molded Case Circuit Breakers and are marked accordingly. This makes them suitable for feeder and branch circuit protection applications in North America.

Supplementary Protectors

As mentioned, the standard Moeller FAZ line fulfills all of the criteria per Code of “Supplementary Overcurrent Protective Devices,” or “Supplementary Protectors,” as they are better known.

What is the definition of a Supplementary Protector per North American standards?

A Supplementary Protector is a manual reset device designed to open the circuit automatically on a pre-determined value of time versus current or voltage within an appliance or other electrical equipment. It may also be provided with manual means for opening or closing the circuit. (Source: UL 1077)

In the US (and similarly in Canada) the NEC 2005 further defines supplementary protectors as devices intended to provide limited overcurrent protection for specific applications, such as lighting fixtures and appliances. This limited protection is *in addition* to the protection provided in the required branch circuit by the branch circuit overcurrent protective device.

Clearly, the underlying message in those definitions is that Supplementary Protectors are not Branch Circuit overcurrent protective devices per Code, and neither are they tested that way per UL and CSA standards. They cannot replace the primary protective role performed by listed and certified molded case circuit breakers and fuses.

That explains, in part, their status by UL as “recognized only” devices. Supplementary Protectors will never bear a UL listing mark, simply because their suitability as protective devices is dependent on a number of acceptability conditions which can vary from make to make and ultimately define the manner in which they can be properly applied per Code. The manufacturer should be consulted in all cases when evaluating the suitability of “recognized only” components such as UL 1077 Supplementary Protectors.

Moeller FAZ protectors are not subject to any specific restrictions in this respect, other than, like all Supplementary Protectors, they must never be used as a substitute for true listed and certified primary overcurrent protective devices.

Where can Supplementary Protectors be used effectively per Code standards?

Moeller’s FAZ Supplementary Protectors can be used in a number of significant areas. To more clearly illustrate potential applications, however, let’s first present the NEC’s definition of a Branch Circuit:

The circuit conductors between the final overcurrent device protecting the circuit and the outlets. (Source: NEC 2005).

A branch circuit is that portion of the electrical distribution system which extends beyond the final branch circuit overcurrent protective device and is intended to serve lighting, appliance, motors and/or other individual loads.

Typically, the Branch Circuit Overcurrent Protective Device (BOPD) will be either a listed molded case circuit breaker or fuse. Supplementary Protectors, such as Moeller’s line of FAZ devices, can therefore be added to any of these branch circuits to “supplement” the branch circuit protection. Examples of applications ideally suited for these devices can include:

- Any type of OEM electrical equipment which is fed from a service panel board and which often requires additional protection for sensitive internal circuitry and components. (Test and medical equipment, copiers and printers, computers and power supplies etc.)
- The need for manual reset devices with optional accessories such as auxiliary contacts and voltage trips to accomplish fuseless protective circuit designs and enhance operational diagnostics.
- Isolation and protection of control cable, coils, contacts and circuit elements of motor control circuits tapped from the load side of the branch circuit protective device. (per NEC 430.72).
- Protection of control circuit transformers, especially in the secondary where the manual reset protector can be used to isolate, as well as protect, secondary circuit conductors and loads.



“Recognized only” mark from UL

All UL 1077 Supplementary Protectors are recognized only devices. They are subject to Conditions of Acceptability in order to be applied properly per the intent of the Electrical Codes.

Primary protection, although permissible, is not an ideal application since these protectors, like fuses, have a fixed current setting not ideally matched to the transformer's primary rated current. A better choice for primary protection of control transformers consists of manual motor controllers additionally evaluated and marked as "Tap Conductor Protectors," such as Moeller's PKZM0 device, since these have an adjustable thermal dial which can be set to the exact primary current rating of the transformer. Consult Moeller for additional information on this application.

IEC based miniature circuit breakers, such as Moeller's entire FAZ line, are much more than just conventional supplementary protectors from an internal design point of view and can provide an ideal means to enhance the protective capabilities of any circuit.

- As mentioned, they are in full compliance with the pertinent EN/IEC standards (EN/IEC 60898, EN/IEC 60947-2) for miniature circuit breakers and can thus be applied, outside of North America, as full-fledged stand-alone overcurrent protective devices in both residential and industrial applications.
- As this typical let-through current curve shows, they are highly current limiting devices which appreciably limit the amount of let-through current and destructive energy within their ratings to minimize damage levels to downstream loads and circuits.

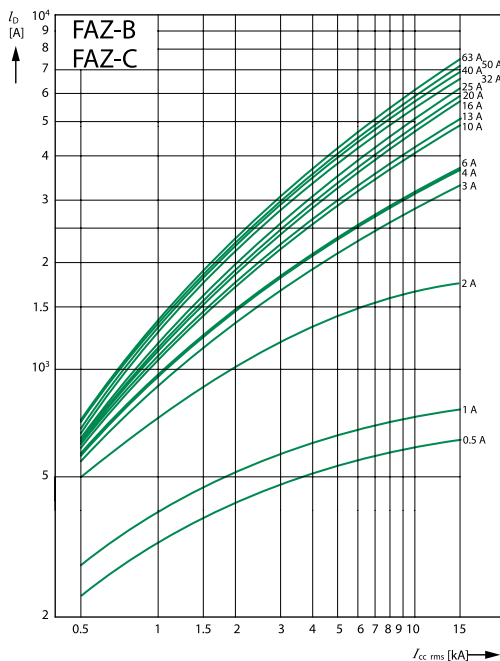

Circuit breakers that are classified as "current limiting" have the ability to clear damaging short circuit currents within the first half cycle of the fault, resulting in better overall protection for all circuit components.

Typical let-through curve profile of a current-limiting device

- The X axis shows the prospective short circuit current levels.
- The Y axis indicates the actual let-through values (Let-through current in the example shown) at those prospective fault ratings for each FAZ device plotted.

As can be interpreted from the bend in the plotted curves, each device acts to limit the damaging let-through energy (and current) at those values of short circuit current.

In a conventional circuit breaker, no similar current limiting effect can be denoted and a device takes at least a few cycles to ultimately clear the fault.

By design, all Moeller FAZ Supplementary Protectors and Miniature Molded Case circuit breakers are current limiting protective devices.

- They come in a variety of tripping characteristics, which is ideal when customizing protection to match specific load requirements. Moeller FAZ Supplementary Protectors offer a total of six different protection characteristics for this purpose: B, C, D, K, S and Z tripping characteristics.
- They feature a number of electrical accessories to enhance the performance and diagnostic capabilities of control panels, as well as a means to facilitate panel mounting and wiring.

Tripping characteristics

Miniature circuit breakers are thermal-magnetic, inverse time tripping devices. From a thermal point of view, all FAZ protectors are calibrated to trip at the same level, which is 135% of the device's fixed current rating for single pole and 145% for multi-pole at an ambient reference temperature of 40°C.

Note: Higher ambient temperatures, as well as density of mounting groups, can all be accommodated but may be subject to de-rating factors. Please consult Moeller technical data for further information and appropriate curves.

It is the response time of the magnetic trip which differentiates each characteristic and for which an identifying letter is assigned. The IEC 898 standard only specifically covers the B, C and D characteristics. The rest can vary from brand to brand, but essentially follow a uniform convention.

The following magnetic response times apply to each of the characteristic letters referenced in Moeller FAZ part numbers:

- B: Instantaneous response between $3..5 \times I_n$ (I_n = fixed current rating of each unit) – Ideally suited for resistive loads, such as conductors or heaters.
- C: Instantaneous response between $5..10 \times I_n$ – Ideally suited for inductive loads, such as motors and solenoids.
- D: Instantaneous response between $10..20 \times I_n$ – Ideally suited for highly inductive loads, such as lighting and higher efficiency motors.
- K: Instantaneous response between $8..12 \times I_n$. – Ideally suited for highly inductive loads, similar to D but with a narrower range.
- S: Instantaneous response between $13..17 \times I_n$ – Ideally suited for highly inductive loads, especially in control circuits with coils and light filaments.
- Z: Instantaneous response between $2..3 \times I_n$ – Very low instantaneous setting to provide tighter protection for loads which are more sensitive to the effects of overcurrents.

A typical Tripping Characteristic curve for FAZ miniature circuit breakers can be seen here:

Typical “Inverse Time” tripping characteristic of a miniature circuit breaker

- “Inverse Time” refers to the device’s tripping characteristic. As the curve shows, the higher the current, the lower the tripping time.
- The trip response on the thermal portion is uniform throughout the line.
- The instantaneous response differs, depending on the characteristic selected. (e.g. B, C or D)
- Tripping is very quick (less than a half cycle) in the upper range of overcurrents (bottom right) due to the current limiting design of Moeller miniature circuit breakers.

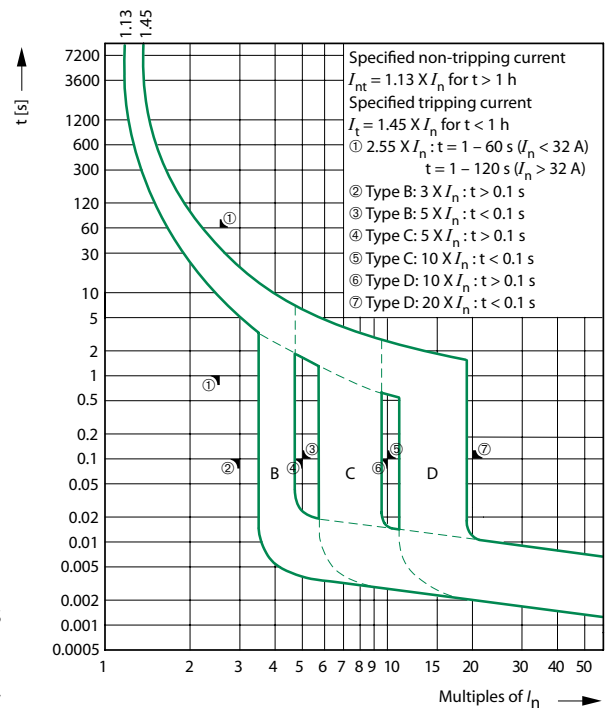

FAZ-NA(RT) Miniature Circuit Breakers

As previously mentioned, Moeller has expanded its FAZ line of miniature circuit breakers to include a version which is listed and certified as a Molded Case Circuit Breaker (UL 489 and CSA No. 5).

This line is rated up to 40A and comes in single, double and triple pole versions with instantaneous trip characteristics C and D. Of course, the line is also in conformity with the IEC standard for molded case circuit breakers, IEC 60947-2, and can therefore be universally applied.

The NEC 2005 defines a circuit breaker as follows:

A device designed to open and close a circuit by nonautomatic means and to open the circuit automatically on a predetermined overcurrent without damage to itself when properly applied within its rating.

Note the text in italics. In the eyes of the Code, that definition sets circuit breakers apart from any other protective device and establishes their role as primary overcurrent protective switches in all types of electrical circuits. UL listing (and CSA Certification) requires additionally that regular testing on circuit breakers be conducted by UL and CSA at the manufacturer’s plant to monitor construction and verify their performance.

Moeller’s new miniature Molded Case Circuit Breaker line includes two types: the FAZ-NA with traditional box terminals for multiple wires, and the FAZ-RT which accommodates ring-tongue terminals. Both versions can utilize a bus bar connection system available with the line.



The advantages of a current limiting device

As already mentioned, all Moeller FAZ devices are current limiting by design. In the case of the UL 489 devices, they are also classified by UL/CSA in that manner and are marked on the label.

A circuit breaker that is marked as a current limiting device is one that does not use a fusible element and, when operating within its current limiting range, limits the let-through energy (I^2t) to less than the energy of a ½ cycle wave of the available symmetrical current.

The label on FAZ-NA(RT) devices lists the actual let-through energy ($I^2t = 45 \text{ kA}^2 \text{ s}$) and peak let-through current (6.2kA) at the maximum interrupting rating of 10kA.

Current limiting circuit breakers substantially reduce the amount of damage sustained by downstream components in the event of a high short circuit fault by clearing the fault in the shortest amount of time possible due to the quick separation of its contacts and ensuing extinction of the arc current.

HACR and SWD

FAZ-NA(RT) circuit breakers are also marked “HACR” for use in Heating, Air Conditioning and Refrigeration applications. In addition, the abbreviation “SWD” on the label indicates the devices are suitable for switching fluorescent lighting loads on a regular basis.

Short Circuit markings on FAZ devices

Below is tabulated summary of short circuit rating values that apply to the FAZ line of Supplementary Protectors and Molded Case circuit breakers.

It is important to keep in mind that short circuit markings on FAZ Supplementary Protectors (UL 1077) and FAZ-NA(RT) Molded Case Circuit breakers (UL 489) must not be interpreted in the same manner.

Supplementary Protectors have short circuit markings in association with upstream primary overcurrent protective devices. Conversely, Molded Case Circuit Breakers *are* primary overcurrent protective devices and their ratings thus refer to their short circuit interrupting capability.

FAZ Supplementary Protectors (UL 1077)	Trip Characteristic	Max. Amps	Max. Volts	Short Circuit Rating
Single pole	B and C	0.5...35A	277 V AC	10kA
		40...63A	277V AC	5kA
		0.5...63A	48V DC	10kA
	D	6...40A	277 V AC	5kA
			48V DC	10kA
2, 3, 4 pole	B and C	0.5...35A	480Y/277V AC ①	10kA
40...63A		480Y/277V AC ①	5kA	
2 poles in series		6...25A	125V DC	10kA
2, 3, 4 pole	D	0.5...40A	480Y/277V AC ①	5kA
2 poles in series			125V DC	10kA
FAZ-(NA)(RT) Branch Circuit Breakers (UL 489)	Trip Characteristic	Max. Amps	Max. Volts	Short Circuit Interrupting Rating
Single pole	C and D	0.5...20A	277 V AC	10kA
		25...40A	240V AC	10kA
2, 3 pole	C and D	0.5...20A	480Y/277V AC ①	10kA
		20...40A	240V AC	10kA

① A circuit breaker with a 480Y/277V AC rating can be applied in a solidly grounded circuit where the nominal voltage of any conductor to ground does not exceed the lower value of the circuit breaker's rating (e.g. 277V AC) and the nominal voltage between any two conductors does not exceed its higher value (480V AC). These ratings can be typically found on protective devices such as molded case circuit breakers, as well as self-protected “Type E” combination motor controllers.

price list
miniature circuit breakers

Use only with Publication FAZ-CAT-CDN
(Article No: 695008)

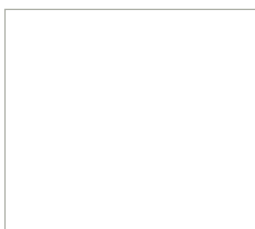
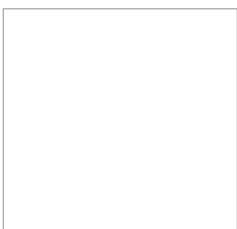
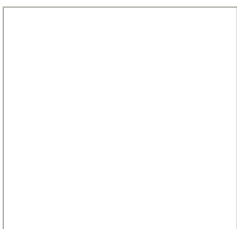

Type	Page	List Price	Discount Schedule
FAZ-C0,5/1-NA	6	28	B22
FAZ-C0,5/1-RT	4	32	B22
FAZ-C0,5/2-NA	6	66	B22
FAZ-C0,5/2-RT	4	72	B22
FAZ-C0,5/3-NA	6	102	B22
FAZ-C0,5/3-RT	4	110	B22
FAZ-C1,5/1-NA	6	28	B22
FAZ-C1,5/1-RT	4	32	B22
FAZ-C1,5/2-NA	6	66	B22
FAZ-C1,5/2-RT	4	72	B22
FAZ-C1,5/3-NA	6	102	B22
FAZ-C1,5/3-RT	4	110	B22
FAZ-C1/1-NA	6	28	B22
FAZ-C1/1-RT	4	32	B22
FAZ-C1/2-NA	6	66	B22
FAZ-C1/2-RT	4	72	B22
FAZ-C1/3-NA	6	102	B22
FAZ-C1/3-RT	4	110	B22
FAZ-C10/1-NA	6	28	B22
FAZ-C10/1-RT	4	32	B22
FAZ-C10/2-NA	6	66	B22
FAZ-C10/2-RT	4	72	B22
FAZ-C10/3-NA	6	102	B22
FAZ-C10/3-RT	4	110	B22
FAZ-C13/1-NA	6	28	B22
FAZ-C13/1-RT	4	32	B22
FAZ-C13/2-NA	6	66	B22
FAZ-C13/2-RT	4	72	B22
FAZ-C13/3-NA	6	102	B22
FAZ-C13/3-RT	4	110	B22
FAZ-C15/1-NA	6	28	B22
FAZ-C15/1-RT	4	32	B22
FAZ-C15/2-NA	6	66	B22
FAZ-C15/2-RT	4	72	B22
FAZ-C15/3-NA	6	102	B22
FAZ-C15/3-RT	4	110	B22
FAZ-C16/1-NA	6	28	B22
FAZ-C16/1-RT	4	32	B22
FAZ-C16/2-NA	6	66	B22
FAZ-C16/2-RT	4	72	B22
FAZ-C16/3-NA	6	102	B22
FAZ-C16/3-RT	4	110	B22
FAZ-C2/1-NA	6	28	B22
FAZ-C2/1-RT	4	32	B22
FAZ-C2/2-NA	6	66	B22
FAZ-C2/2-RT	4	72	B22
FAZ-C2/3-NA	6	102	B22
FAZ-C2/3-RT	4	110	B22
FAZ-C20/1-NA	6	28	B22
FAZ-C20/1-RT	4	32	B22
FAZ-C20/2-NA	6	66	B22
FAZ-C20/2-RT	4	72	B22
FAZ-C20/3-NA	6	102	B22
FAZ-C20/3-RT	4	110	B22
FAZ-C25/1-NA	6	28	B22
FAZ-C25/1-RT	4	32	B22
FAZ-C25/2-NA	6	66	B22
FAZ-C25/2-RT	4	72	B22
FAZ-C25/3-NA	6	102	B22
FAZ-C25/3-RT	4	110	B22
FAZ-C3/1-NA	6	28	B22
FAZ-C3/1-RT	4	32	B22
FAZ-C3/2-NA	6	66	B22

Type	Page	List Price	Discount Schedule
FAZ-C3/2-RT	4	72	B22
FAZ-C3/3-NA	6	102	B22
FAZ-C3/3-RT	4	110	B22
FAZ-C30/1-NA	6	28	B22
FAZ-C30/1-RT	4	32	B22
FAZ-C30/2-NA	6	66	B22
FAZ-C30/2-RT	4	72	B22
FAZ-C30/3-NA	6	102	B22
FAZ-C30/3-RT	4	110	B22
FAZ-C32/1-NA	6	28	B22
FAZ-C32/1-RT	4	32	B22
FAZ-C32/2-NA	6	66	B22
FAZ-C32/2-RT	4	72	B22
FAZ-C32/3-NA	6	102	B22
FAZ-C32/3-RT	4	110	B22
FAZ-C35/1-NA	6	28	B22
FAZ-C35/1-RT	4	32	B22
FAZ-C35/2-NA	6	66	B22
FAZ-C35/2-RT	4	72	B22
FAZ-C35/3-NA	6	102	B22
FAZ-C35/3-RT	4	110	B22
FAZ-C4/1-NA	6	28	B22
FAZ-C4/1-RT	4	32	B22
FAZ-C4/2-NA	6	66	B22
FAZ-C4/2-RT	4	72	B22
FAZ-C4/3-NA	6	102	B22
FAZ-C4/3-RT	4	110	B22
FAZ-C40/1-NA	6	28	B22
FAZ-C40/1-RT	4	32	B22
FAZ-C40/2-NA	6	66	B22
FAZ-C40/2-RT	4	72	B22
FAZ-C40/3-NA	6	102	B22
FAZ-C40/3-RT	4	110	B22
FAZ-C5/1-NA	6	28	B22
FAZ-C5/1-RT	4	32	B22
FAZ-C5/2-NA	6	66	B22
FAZ-C5/2-RT	4	72	B22
FAZ-C5/3-NA	6	102	B22
FAZ-C5/3-RT	4	110	B22
FAZ-C6/1-NA	6	28	B22
FAZ-C6/1-RT	4	32	B22
FAZ-C6/2-NA	6	66	B22
FAZ-C6/2-RT	4	72	B22
FAZ-C6/3-NA	6	102	B22
FAZ-C6/3-RT	4	110	B22
FAZ-C7/1-NA	6	28	B22
FAZ-C7/1-RT	4	32	B22
FAZ-C7/2-NA	6	66	B22
FAZ-C7/2-RT	4	72	B22
FAZ-C7/3-NA	6	102	B22
FAZ-C7/3-RT	4	110	B22
FAZ-C8/1-NA	6	28	B22
FAZ-C8/1-RT	4	32	B22
FAZ-C8/2-NA	6	66	B22
FAZ-C8/2-RT	4	72	B22
FAZ-C8/3-NA	6	102	B22
FAZ-C8/3-RT	5	110	B22
FAZ-D0,5/1-NA	7	32	B22
FAZ-D0,5/1-RT	5	36	B22
FAZ-D0,5/2-NA	7	74	B22
FAZ-D0,5/2-RT	5	82	B22
FAZ-D0,5/3-NA	7	114	B22
FAZ-D0,5/3-RT	5	124	B22

Type	Page	List Price	Discount Schedule
FAZ-D1,5/1-NA	7	32	B22
FAZ-D1,5/1-RT	5	36	B22
FAZ-D1,5/2-NA	7	74	B22
FAZ-D1,5/2-RT	5	82	B22
FAZ-D1,5/3-NA	7	114	B22
FAZ-D1,5/3-RT	5	124	B22
FAZ-D1/1-NA	7	32	B22
FAZ-D1/1-RT	5	36	B22
FAZ-D1/2-NA	7	74	B22
FAZ-D1/2-RT	5	82	B22
FAZ-D1/3-NA	7	114	B22
FAZ-D1/3-RT	5	124	B22
FAZ-D10/1-NA	7	32	B22
FAZ-D10/1-RT	5	36	B22
FAZ-D10/2-NA	7	74	B22
FAZ-D10/2-RT	5	82	B22
FAZ-D10/3-NA	7	114	B22
FAZ-D10/3-RT	5	124	B22
FAZ-D13/1-NA	7	32	B22
FAZ-D13/1-RT	5	36	B22
FAZ-D13/2-NA	7	74	B22
FAZ-D13/2-RT	5	82	B22
FAZ-D13/3-NA	7	114	B22
FAZ-D13/3-RT	5	124	B22
FAZ-D15/1-NA	7	32	B22
FAZ-D15/1-RT	5	36	B22
FAZ-D15/2-NA	7	74	B22
FAZ-D15/2-RT	5	82	B22
FAZ-D15/3-NA	7	114	B22
FAZ-D15/3-RT	5	124	B22
FAZ-D16/1-NA	7	32	B22
FAZ-D16/1-RT	5	36	B22
FAZ-D16/2-NA	7	74	B22
FAZ-D16/2-RT	5	82	B22
FAZ-D16/3-NA	7	114	B22
FAZ-D16/3-RT	5	124	B22
FAZ-D2/1-NA	7	32	B22
FAZ-D2/1-RT	5	36	B22
FAZ-D2/2-NA	7	74	B22
FAZ-D2/2-RT	5	82	B22
FAZ-D2/3-NA	7	114	B22
FAZ-D2/3-RT	5	124	B22
FAZ-D20/1-NA	7	32	B22
FAZ-D20/1-RT	5	36	B22
FAZ-D20/2-NA	7	74	B22
FAZ-D20/2-RT	5	82	B22
FAZ-D20/3-NA	7	114	B22
FAZ-D20/3-RT	5	124	B22
FAZ-D25/1-NA	7	32	B22
FAZ-D25/1-RT	5	36	B22
FAZ-D25/2-NA	7	74	B22
FAZ-D25/2-RT	5	82	B22
FAZ-D25/3-NA	7	114	B22
FAZ-D25/3-RT	5	124	B22
FAZ-D3/1-NA	7	32	B22
FAZ-D3/1-RT	5	36	B22
FAZ-D3/2-NA	7	74	B22
FAZ-D3/2-RT	5	82	B22
FAZ-D3/3-NA	7	114	B22
FAZ-D3/3-RT	5	124	B22
FAZ-D30/1-NA	7	32	B22
FAZ-D30/1-RT	5	36	B22
FAZ-D30/2-NA	7	74	B22

Type	Page	List Price	Discount Schedule
FAZ-D30/2-RT	5	82	B22
FAZ-D30/3-NA	7	114	B22
FAZ-D30/3-RT	5	124	B22
FAZ-D32/1-NA	7	32	B22
FAZ-D32/1-RT	5	36	B22
FAZ-D32/2-NA	7	74	B22
FAZ-D32/2-RT	5	82	B22
FAZ-D32/3-NA	7	114	B22
FAZ-D32/3-RT	5	124	B22
FAZ-D35/1-NA	7	32	B22
FAZ-D35/1-RT	5	36	B22
FAZ-D35/2-NA	7	74	B22
FAZ-D35/2-RT	5	82	B22
FAZ-D35/3-NA	7	114	B22
FAZ-D35/3-RT	5	124	B22
FAZ-D4/1-NA	7	32	B22
FAZ-D4/1-RT	5	36	B22
FAZ-D4/2-NA	7	74	B22
FAZ-D4/2-RT	5	82	B22
FAZ-D4/3-NA	7	114	B22
FAZ-D4/3-RT	5	124	B22
FAZ-D40/1-NA	7	32	B22
FAZ-D40/1-RT	5	36	B22
FAZ-D40/2-NA	7	74	B22
FAZ-D40/2-RT	5	82	B22
FAZ-D40/3-NA	7	114	B22
FAZ-D40/3-RT	5	124	B22
FAZ-D5/1-NA	7	32	B22
FAZ-D5/1-RT	5	36	B22
FAZ-D5/2-NA	7	74	B22
FAZ-D5/2-RT	5	82	B22
FAZ-D5/3-NA	7	114	B22
FAZ-D5/3-RT	5	124	B22
FAZ-D6/1-NA	7	32	B22
FAZ-D6/1-RT	5	36	B22
FAZ-D6/2-NA	7	74	B22
FAZ-D6/2-RT	5	82	B22
FAZ-D6/3-NA	7	114	B22
FAZ-D6/3-RT	5	124	B22
FAZ-D7/1-NA	7	32	B22
FAZ-D7/1-RT	5	36	B22
FAZ-D7/2-NA	7	74	B22
FAZ-D7/2-RT	5	82	B22
FAZ-D7/3-NA	7	114	B22
FAZ-D7/3-RT	5	124	B22
FAZ-D8/1-NA	7	32	B22
FAZ-D8/1-RT	5	36	B22
FAZ-D8/2-NA	7	74	B22
FAZ-D8/2-RT	5	82	B22
FAZ-D8/3-NA	7	114	B22
FAZ-D8/3-RT	8	124	B22
FAZ-XAA-NA110-415VAC	8	60	B22
FAZ-XAA-NA12-110VAC	8	60	B22
IS/SPE-1TE	8	25	B22
Z-NHK	6	40	B22

Alphabetical Listing by Type

Type	Page	List Price	Discount Schedule
EVG-16/1PHAS/12MODUL	33	11	B
EVG-16/1PHAS/2MODUL	33	4	B
EVG-16/1PHAS/2MODUL/HI	33	7	B
EVG-16/1PHAS/6MODUL	33	8	B
EVG-16/1PHAS/6MODUL/HI	33	15	B
EVG-16/1PHAS/9MODUL/HI	33	18	B
EVG-16/2PHAS/10MODUL/HI	33	24	B
EVG-16/2PHAS/12MODUL	33	24	B
EVG-16/2PHAS/4MODUL	33	12	B
EVG-16/2PHAS/4MODUL/HI	33	15	B
EVG-16/2PHAS/6MODUL	33	15	B
EVG-16/2PHAS/6MODUL/HI	33	20	B
EVG-16/3PHAS/12MODUL	33	32	B
EVG-16/3PHAS/12MODUL/HI	33	35	B
EVG-16/3PHAS/6MODUL	33	20	B
EVG-16/3PHAS/6MODUL/HI	33	22	B
EVG-16/4PHAS/12MODUL	33	52	B
EVG-16/4PHAS/8MODUL	33	35	B
FAZ/FIP-XSV	34	8	B
FAZ-B10/1	22	18	B
FAZ-B10/1N	23	32	B
FAZ-B10/2	22	50	B
FAZ-B10/3	22	80	B
FAZ-B10/3N	23	95	B
FAZ-B10/4	22	100	B
FAZ-B12/1	22	18	B
FAZ-B12/1N	23	32	B
FAZ-B12/2	22	50	B
FAZ-B12/3	22	80	B
FAZ-B12/3N	23	95	B
FAZ-B12/4	22	100	B
FAZ-B13/1	22	18	B
FAZ-B13/1N	23	32	B
FAZ-B13/2	22	50	B
FAZ-B13/3	22	80	B
FAZ-B13/3N	23	95	B
FAZ-B13/4	22	100	B
FAZ-B15/1	22	18	B
FAZ-B15/1N	23	32	B
FAZ-B15/2	22	50	B
FAZ-B15/3	22	80	B
FAZ-B15/3N	23	95	B
FAZ-B15/4	22	100	B
FAZ-B16/1	22	18	B
FAZ-B16/1N	23	32	B
FAZ-B16/2	22	50	B
FAZ-B16/3	22	80	B
FAZ-B16/3N	23	95	B
FAZ-B16/4	22	100	B
FAZ-B20/1	22	18	B
FAZ-B20/1N	23	32	B
FAZ-B20/2	22	50	B
FAZ-B20/3	22	80	B
FAZ-B20/3N	23	95	B
FAZ-B20/4	22	100	B
FAZ-B25/1	22	18	B
FAZ-B25/1N	23	32	B
FAZ-B25/2	22	50	B
FAZ-B25/3	22	80	B
FAZ-B25/3N	23	95	B
FAZ-B25/4	22	100	B
FAZ-B32/1	22	18	B
FAZ-B32/1N	23	32	B

Type	Page	List Price	Discount Schedule
FAZ-B32/2	22	50	B
FAZ-B32/3	22	80	B
FAZ-B32/3N	23	95	B
FAZ-B32/4	22	100	B
FAZ-B40/1	22	18	B
FAZ-B40/1N	23	32	B
FAZ-B40/2	22	50	B
FAZ-B40/3	22	80	B
FAZ-B40/3N	23	95	B
FAZ-B40/4	22	100	B
FAZ-B50/1	22	24	B
FAZ-B50/1N	23	38	B
FAZ-B50/2	22	60	B
FAZ-B50/3	22	100	B
FAZ-B50/3N	23	120	B
FAZ-B50/4	22	125	B
FAZ-B6/1	22	18	B
FAZ-B6/1N	23	32	B
FAZ-B6/2	22	50	B
FAZ-B6/3	22	80	B
FAZ-B6/3N	23	95	B
FAZ-B6/4	22	100	B
FAZ-B63/1	22	30	B
FAZ-B63/1N	23	46	B
FAZ-B63/2	22	80	B
FAZ-B63/3	22	135	B
FAZ-B63/3N	23	155	B
FAZ-B63/4	22	160	B
FAZ-B8/1	22	18	B
FAZ-B8/1N	23	32	B
FAZ-B8/2	22	50	B
FAZ-B8/3	22	80	B
FAZ-B8/3N	23	95	B
FAZ-B8/4	22	100	B
FAZ-C0,5/1	24	21	B
FAZ-C0,5/1N	25	35	B
FAZ-C0,5/2	24	48	B
FAZ-C0,5/3	24	76	B
FAZ-C0,5/3N	25	100	B
FAZ-C0,5/4	24	110	B
FAZ-C1,6/1	24	21	B
FAZ-C1,6/1N	25	35	B
FAZ-C1,6/2	24	48	B
FAZ-C1,6/3	24	76	B
FAZ-C1,6/3N	25	100	B
FAZ-C1,6/4	24	110	B
FAZ-C1/1	24	21	B
FAZ-C1/1N	25	35	B
FAZ-C1/2	24	48	B
FAZ-C1/3	24	76	B
FAZ-C1/3N	25	100	B
FAZ-C1/4	24	110	B
FAZ-C10/1	24	21	B
FAZ-C10/1N	25	35	B
FAZ-C10/2	24	48	B
FAZ-C10/3	24	76	B
FAZ-C10/3N	25	100	B
FAZ-C10/4	24	110	B
FAZ-C13/1	24	21	B
FAZ-C13/1N	25	35	B
FAZ-C13/2	24	48	B
FAZ-C13/3	24	76	B
FAZ-C13/3N	25	100	B

Type	Page	List Price	Discount Schedule
FAZ-C13/4	24	110	B
FAZ-C16/1	24	21	B
FAZ-C16/1N	25	35	B
FAZ-C16/2	24	48	B
FAZ-C16/3	24	76	B
FAZ-C16/3N	25	100	B
FAZ-C16/4	24	110	B
FAZ-C2/1	24	21	B
FAZ-C2/1N	25	35	B
FAZ-C2/2	24	48	B
FAZ-C2/3	24	76	B
FAZ-C2/3N	25	100	B
FAZ-C2/4	24	110	B
FAZ-C20/1	24	21	B
FAZ-C20/1N	25	35	B
FAZ-C20/2	24	48	B
FAZ-C20/3	24	76	B
FAZ-C20/3N	25	100	B
FAZ-C20/4	24	110	B
FAZ-C25/1	24	21	B
FAZ-C25/1N	25	35	B
FAZ-C25/2	24	48	B
FAZ-C25/3	24	76	B
FAZ-C25/3N	25	100	B
FAZ-C25/4	24	110	B
FAZ-C3/1	24	21	B
FAZ-C3/1N	25	35	B
FAZ-C3/2	24	48	B
FAZ-C3/3	24	76	B
FAZ-C3/3N	25	100	B
FAZ-C3/4	24	110	B
FAZ-C32/1	24	21	B
FAZ-C32/1N	25	35	B
FAZ-C32/2	24	48	B
FAZ-C32/3	24	76	B
FAZ-C32/3N	25	100	B
FAZ-C32/4	24	110	B
FAZ-C4/1	24	21	B
FAZ-C4/1N	25	35	B
FAZ-C4/2	24	48	B
FAZ-C4/3	24	76	B
FAZ-C4/3N	25	100	B
FAZ-C4/4	24	110	B
FAZ-C40/1	24	21	B
FAZ-C40/1N	25	35	B
FAZ-C40/2	24	48	B
FAZ-C40/3	24	76	B
FAZ-C40/3N	25	100	B
FAZ-C40/4	24	110	B
FAZ-C50/1	24	30	B
FAZ-C50/1N	25	45	B
FAZ-C50/2	24	66	B
FAZ-C50/3	24	120	B
FAZ-C50/3N	25	145	B
FAZ-C50/4	24	150	B
FAZ-C6/1	24	21	B
FAZ-C6/1N	25	35	B
FAZ-C6/2	24	48	B
FAZ-C6/3	24	76	B
FAZ-C6/3N	25	100	B
FAZ-C6/4	24	110	B
FAZ-C63/1	24	40	B
FAZ-C63/1N	25	55	B

Type	Page	List Price	Discount Schedule
FAZ-C63/2	24	78	B
FAZ-C63/3	24	130	B
FAZ-C63/3N	25	160	B
FAZ-C63/4	24	185	B
FAZ-C8/1	24	21	B
FAZ-C8/1N	25	35	B
FAZ-C8/2	24	48	B
FAZ-C8/3	24	76	B
FAZ-C8/3N	25	100	B
FAZ-C8/4	24	110	B
FAZ-D10/1	26	24	B
FAZ-D10/2	26	50	B
FAZ-D10/3	26	85	B
FAZ-D10/3N	27	105	B
FAZ-D10/4	26	112	B
FAZ-D13/1	26	24	B
FAZ-D13/2	26	50	B
FAZ-D13/3	26	85	B
FAZ-D13/3N	27	105	B
FAZ-D13/4	26	112	B
FAZ-D16/1	26	24	B
FAZ-D16/2	26	50	B
FAZ-D16/3	26	85	B
FAZ-D16/3N	27	105	B
FAZ-D16/4	26	112	B
FAZ-D20/1	26	24	B
FAZ-D20/2	26	50	B
FAZ-D20/3	26	85	B
FAZ-D20/3N	27	105	B
FAZ-D20/4	26	112	B
FAZ-D25/1	26	24	B
FAZ-D25/2	26	50	B
FAZ-D25/3	26	85	B
FAZ-D25/3N	27	105	B
FAZ-D25/4	26	112	B
FAZ-D32/1	26	24	B
FAZ-D32/2	26	50	B
FAZ-D32/3	26	85	B
FAZ-D32/3N	27	105	B
FAZ-D32/4	26	112	B
FAZ-D40/1	26	24	B
FAZ-D40/2	26	50	B
FAZ-D40/3	26	85	B
FAZ-D40/3N	27	105	B
FAZ-D40/4	26	112	B
FAZ-D6/1	26	24	B
FAZ-D6/2	26	50	B
FAZ-D6/3	26	85	B
FAZ-D6/3N	27	105	B
FAZ-D6/4	26	112	B
FAZ-D8/1	26	24	B
FAZ-D8/2	26	50	B
FAZ-D8/3	26	85	B
FAZ-D8/3N	27	105	B
FAZ-D8/4	26	112	B
FAZ-K0,5/1	28	22	B
FAZ-K0,5/2	28	55	B
FAZ-K0,5/3	28	90	B
FAZ-K0,5/3N	29	105	B
FAZ-K0,5/4	28	115	B
FAZ-K1,6/1	28	22	B
FAZ-K1,6/2	28	55	B
FAZ-K1,6/3	28	90	B

Alphabetical Listing by Type

Type	Page	List Price	Discount Schedule
FAZ-K1,6/3N	29	105	B
FAZ-K1,6/4	28	115	B
FAZ-K1/1	28	22	B
FAZ-K1/2	28	55	B
FAZ-K1/3	28	90	B
FAZ-K1/3N	29	105	B
FAZ-K1/4	28	115	B
FAZ-K10/1	28	22	B
FAZ-K10/2	28	55	B
FAZ-K10/3	28	90	B
FAZ-K10/3N	29	105	B
FAZ-K10/4	28	115	B
FAZ-K13/1	28	22	B
FAZ-K13/2	28	55	B
FAZ-K13/3	28	90	B
FAZ-K13/3N	29	105	B
FAZ-K13/4	28	115	B
FAZ-K16/1	28	22	B
FAZ-K16/2	28	55	B
FAZ-K16/3	28	90	B
FAZ-K16/3N	29	105	B
FAZ-K16/4	28	115	B
FAZ-K2/1	28	22	B
FAZ-K2/2	28	55	B
FAZ-K2/3	28	90	B
FAZ-K2/3N	29	105	B
FAZ-K2/4	28	115	B
FAZ-K20/1	28	22	B
FAZ-K20/2	28	55	B
FAZ-K20/3	28	90	B
FAZ-K20/3N	29	105	B
FAZ-K20/4	28	115	B
FAZ-K25/1	28	22	B
FAZ-K25/2	28	55	B
FAZ-K25/3	28	90	B
FAZ-K25/3N	29	105	B
FAZ-K25/4	28	115	B
FAZ-K3/1	28	22	B
FAZ-K3/2	28	55	B
FAZ-K3/3	28	90	B
FAZ-K3/3N	29	105	B
FAZ-K3/4	28	115	B
FAZ-K32/1	28	22	B
FAZ-K32/2	28	55	B
FAZ-K32/3	28	90	B
FAZ-K32/3N	29	105	B
FAZ-K32/4	28	115	B
FAZ-K4/1	28	22	B
FAZ-K4/2	28	55	B
FAZ-K4/3	28	90	B
FAZ-K4/3N	29	105	B
FAZ-K4/4	28	115	B
FAZ-K40/1	28	22	B
FAZ-K40/2	28	55	B
FAZ-K40/3	28	90	B
FAZ-K40/3N	29	105	B
FAZ-K40/4	28	115	B
FAZ-K50/1	28	35	B
FAZ-K50/2	28	80	B
FAZ-K50/3	28	135	B
FAZ-K50/3N	29	150	B
FAZ-K50/4	28	150	B
FAZ-K6/1	28	22	B

Type	Page	List Price	Discount Schedule
FAZ-K6/2	28	55	B
FAZ-K6/3	28	90	B
FAZ-K6/3N	29	105	B
FAZ-K6/4	28	115	B
FAZ-K63/1	28	40	B
FAZ-K63/2	28	90	B
FAZ-K63/3	28	155	B
FAZ-K63/3N	29	175	B
FAZ-K63/4	28	190	B
FAZ-K8/1	28	22	B
FAZ-K8/2	28	55	B
FAZ-K8/3	28	90	B
FAZ-K8/3N	29	105	B
FAZ-K8/4	28	115	B
FAZ-S1/1	31	15	B
FAZ-S1/2	31	35	B
FAZ-S10/1	31	15	B
FAZ-S10/2	31	35	B
FAZ-S16/1	31	15	B
FAZ-S16/2	31	35	B
FAZ-S2/1	31	15	B
FAZ-S2/2	31	35	B
FAZ-S20/1	31	18	B
FAZ-S20/2	31	50	B
FAZ-S25/1	31	20	B
FAZ-S25/2	31	55	B
FAZ-S3/1	31	15	B
FAZ-S3/2	31	35	B
FAZ-S32/1	31	22	B
FAZ-S32/2	31	60	B
FAZ-S4/1	31	15	B
FAZ-S4/2	31	35	B
FAZ-S40/1	31	26	B
FAZ-S40/2	31	70	B
FAZ-S6/1	31	15	B
FAZ-S6/2	31	35	B
FAZ-XAA-C-110-415VAC	32	40	B
FAZ-XAA-C-12-110VAC	32	40	B
FAZ-XAM002	32	30	B
FAZ-XBS	34	10	B
FAZ-XH11	32	18	B
FAZ-XK25	34	10	B
FAZ-XK35	34	20	B
FAZ-XUA(115VAC)	32	65	B
FAZ-XUA(230VAC)	32	65	B
FAZ-XUA(400VAC)	32	65	B
FAZ-Z0,5/1	30	22	B
FAZ-Z0,5/2	30	55	B
FAZ-Z0,5/3	30	90	B
FAZ-Z0,5/4	30	115	B
FAZ-Z1,6/1	30	22	B
FAZ-Z1,6/2	30	55	B
FAZ-Z1,6/3	30	90	B
FAZ-Z1,6/4	30	115	B
FAZ-Z1/1	30	22	B
FAZ-Z1/2	30	55	B
FAZ-Z1/3	30	90	B
FAZ-Z1/4	30	115	B
FAZ-Z10/1	30	22	B
FAZ-Z10/2	30	55	B
FAZ-Z10/3	30	90	B
FAZ-Z10/4	30	115	B
FAZ-Z16/1	30	22	B

Type	Page	List Price	Discount Schedule
FAZ-Z16/2	30	55	B
FAZ-Z16/3	30	90	B
FAZ-Z16/4	30	115	B
FAZ-Z2/1	30	22	B
FAZ-Z2/2	30	55	B
FAZ-Z2/3	30	90	B
FAZ-Z2/4	30	115	B
FAZ-Z20/1	30	22	B
FAZ-Z20/2	30	55	B
FAZ-Z20/3	30	90	B
FAZ-Z20/4	30	115	B
FAZ-Z25/1	30	22	B
FAZ-Z25/2	30	55	B
FAZ-Z25/3	30	90	B
FAZ-Z25/4	30	115	B
FAZ-Z3/1	30	22	B
FAZ-Z3/2	30	55	B
FAZ-Z3/3	30	90	B
FAZ-Z3/4	30	115	B
FAZ-Z32/1	30	22	B
FAZ-Z32/2	30	55	B
FAZ-Z32/3	30	90	B
FAZ-Z32/4	30	115	B
FAZ-Z4/1	30	22	B
FAZ-Z4/2	30	55	B
FAZ-Z4/3	30	90	B
FAZ-Z4/4	30	115	B
FAZ-Z40/1	30	22	B
FAZ-Z40/2	30	55	B
FAZ-Z40/3	30	90	B
FAZ-Z40/4	30	115	B
FAZ-Z50/1	30	35	B
FAZ-Z50/2	30	80	B
FAZ-Z50/3	30	135	B
FAZ-Z50/4	30	150	B
FAZ-Z6/1	30	22	B
FAZ-Z6/2	30	55	B
FAZ-Z6/3	30	90	B
FAZ-Z6/4	30	115	B
FAZ-Z63/1	30	45	B
FAZ-Z63/2	30	90	B
FAZ-Z63/3	30	155	B
FAZ-Z63/4	30	190	B
FAZ-Z8/1	30	22	B
FAZ-Z8/2	30	55	B
FAZ-Z8/3	30	90	B
FAZ-Z8/4	30	115	B
REG-BB	34	10	B



www.moeller.ca

Moeller Canadian Head Office

7275 Rapistan Court
Mississauga, Ontario CANADA
L5N 5Z4

Tel 905.542.2323

Fax 905.542.2321

Moeller Corporate Headquarters

4140 World Houston Parkway, N° 100
Houston, Texas USA 77032

Tel 713.933.0999

Fax 832.613.6255

© 2006 by Moeller, Inc.
Technical and other changes reserved.
Publication: FAZ-CAT-CDN-0706
Article No: 695008

